



**ANVIL**

# Installation, Operation and Care Manual



SCAN ME  
TO GO TO  
WARRANTY  
REGISTRATION

MANUFACTURING  
SINCE 1966

4-INS-POA1001

THE CHEFS COMPANION

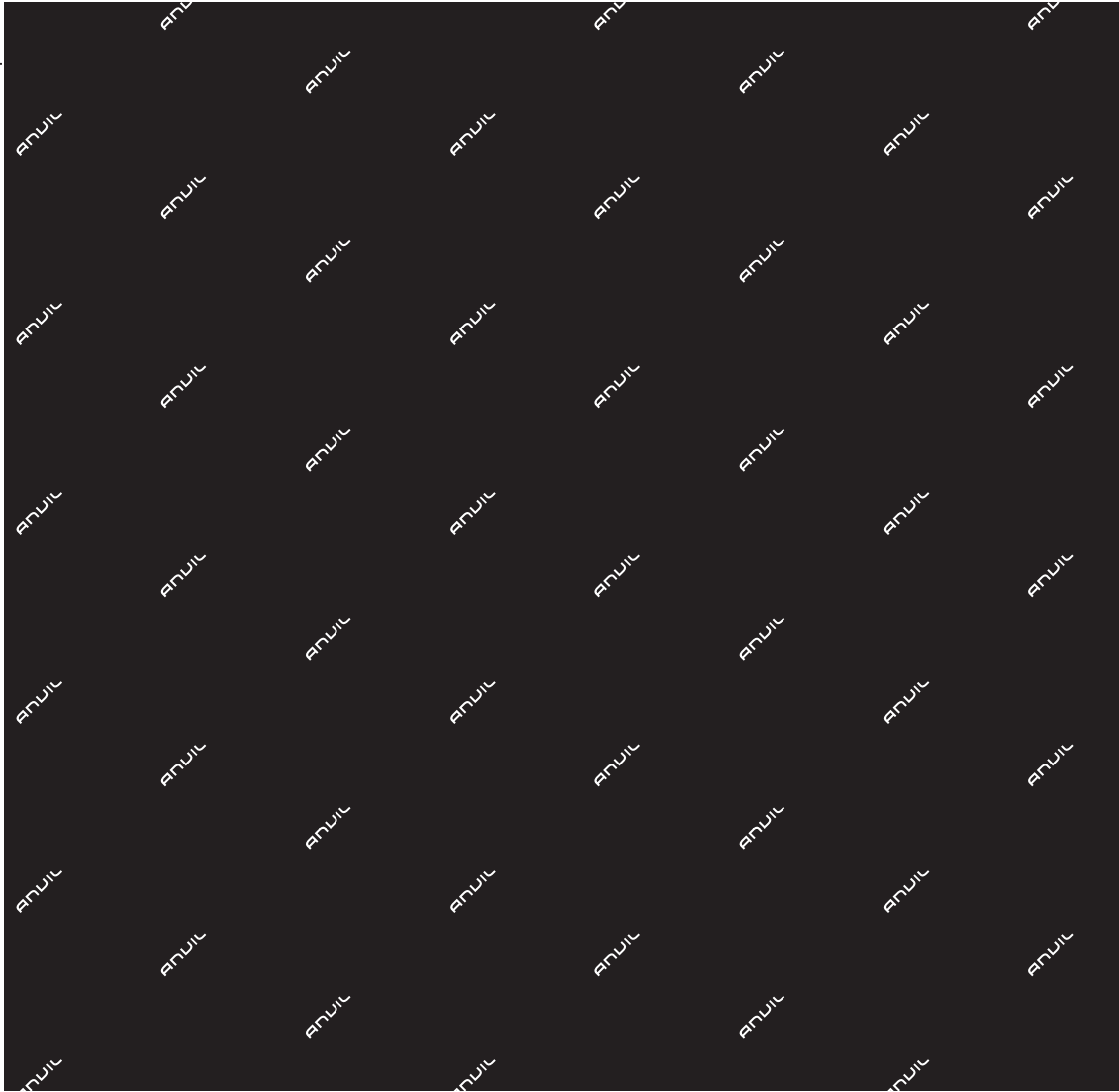

THE CHEFS COMPANION



THANK YOU FOR PURCHASING AN ANVIL PRODUCT!



**REGISTER ONLINE TODAY**

Register your warranty on-line at [www.anvilworld.com](http://www.anvilworld.com) today and learn how to get the best out of your Anvil product, tips to care for your Anvil product for long lasting performance, exciting recipes and more.

**NO WEB ACCESS?**

If you do not have access to the Web, register by completing this form and faxing it to the Anvil head office in South Africa. Fax: +27 11 474 1630

**ONLY COMPLETE IF YOU DO NOT HAVE WEB ACCESS**

Company \_\_\_\_\_

Name \_\_\_\_\_

Surname \_\_\_\_\_

Telephone \_\_\_\_\_

Cellphone \_\_\_\_\_

Email Address \_\_\_\_\_

Country \_\_\_\_\_

Postal address \_\_\_\_\_

\_\_\_\_\_

\_\_\_\_\_

Anvil products purchased \_\_\_\_\_

Code (see box label) \_\_\_\_\_

Serial number (see back of machine) \_\_\_\_\_

**INTENDED USE**

- Full-Service restaurant
- Coffee Shop / Deli
- Fast Food Outlet
- Hotel
- Bed & Breakfast
- School Cafeteria

- Institutional Cafeteria
- Corporate Catering
- Private Use
- Franchisor
- Convenience Store
- Other

 ALL ANVIL EQUIPMENT COMES WITH A TWO YEAR WARRANTY ON COMPONENTS AND DEFECTIVE WORKMANSHIP.

[www.anvilworld.com](http://www.anvilworld.com)

## LIMITED WARRANTY

All equipment which is sold under ANVIL trademark and used for commercial purposes is warranted against defects in materials and workmanship. The warranty runs for two years from the date of original installation and is for the benefit of the original purchaser only. All other Warranties ,expressed or implied , statutory or otherwise, including without limitations any implied Warranty of Merchantability or fitness for purpose are excluded .The Seller shall in no event be liable for direct,indirect or consequential damages in connection with ANVIL commercial products.

The Sellers obligation under this Warranty is limited to the repair of defects without charge. Defective units must be taken or shipped,transportation charges prepaid,to ANVIL.

This Warranty is not effective if damage occurs because of accident,carelessness,improper installation,lack of proper set-up,supervision when required or if the equipment is installed or operated in any manner contrary to the installation and operating instructions. In these cases,repairs will be made at a reasonable cost. Work performed by unauthorized personnel or unauthorized service agencies using non Anvil spares voids this Warranty.

## COUNTER TOP PIZZA OVEN

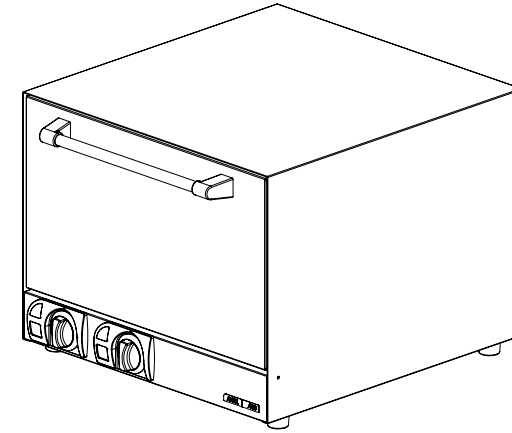

**NB:**

### REGISTER ON-LINE TODAY

Register your warranty on-line now at [www.anvilworld.com](http://www.anvilworld.com)

### NO WEB ACCESS

If you do not have access to the Web. Kindly register by completing the warranty registration form and fax it to the ANVIL office in the country of purchase.

**Failure to do so will invalidate your warranty.**

**INSTALLATION OPERATION AND CARE OF  
COUNTER TOP PIZZA OVEN  
MODEL: POA1001 R02**

## UNPACKING

Unpack the product and check for any damage incurred during transit. This should be reported to the responsible carrier, railway or postal authority, and a request for a damage report should be made.



THESE INSTRUCTIONS MUST BE FOLLOWED FOR US TO GUARANTEE OUR FULL SUPPORT OF YOUR CLAIM FOR PROTECTING AGAINST LOSS FROM CONCEALED DAMAGE. THE FORM FOR FILING SUCH A CLAIM WILL BE PROVIDED BY THE CARRIER.

## GENERAL INSTALLATION AND OPERATION INSTRUCTIONS

Anvil Counter top pizza ovens have been designed for the baking of pizza and bread products in direct contact with the ceramic decks. Any other products must be placed in a suitable pan for baking.

1. Protective Film - Carefully remove the protective film from the stainless steel before using oven for the first time. If any glue residue should remain, remove it with a suitable solvent recommended for stainless steel. It is important to remove this film before installation and use otherwise it will stick onto the stainless steel and become very difficult to remove thereafter.
2. Positioning - Install the counter top pizza oven in the most convenient location for ease of cleaning, maintenance and general operation. The unit should be placed a minimum distance of 100mm from any adjacent wall. If this appliance is to be positioned in close proximity to a wall, partitions, kitchen furniture, decorative finishes, etc. it is recommended that they be made of Non – combustible materials. If not, they shall be clad with a suitable non – combustible heat insulating material, and the closest attention be paid to the fire prevention regulations.
3. Grounding - These counter top pizza ovens require a grounded, receptacle.

## MODEL: COUNTER TOP PIZZA OVEN

MODEL CODE : POA1001 R02

| Part No. | Description          |
|----------|----------------------|
| 1        | BACK PANEL           |
| 2        | POWER CORD           |
| 3        | CABLE GRIP           |
| 4        | CONNECTOR BLOCK      |
| 5        | ELEMENT              |
| 6        | TOP ELEMENT          |
| 7        | BODY PANEL           |
| 8        | SHELF ASSEMBLY       |
| 9        | FRONT CONTROL PANEL  |
| 10       | CONTROL THERMOSTAT   |
| 11       | SELECTOR SWITCH      |
| 12       | CONTROL PANEL FACIA  |
| 13       | BEZEL                |
| 14       | CONTROL PANEL INSERT |
| 15       | CONTROL KNOB         |
| 16       | PILOT LIGHT          |
| 17       | INNER DOOR PANEL     |
| 18       | DOOR HINGE           |
| 19       | OUTER DOOR PANEL     |
| 20       | DOOR NODE            |
| 21       | DOOR HANDLE TUBE     |
| 22       | 15 MIN TIMER         |
| 23       | CONTROL PANEL INSERT |
| 24       | ANVIL AXIS LOGO      |
| 25       | BOTTOM COVER BRACE   |
| 26       | RUBBER FOOT          |
| 27       | BOTTOM PANEL         |
| 28       | SHELF STOP BOTTOM    |
| 29       | BAKING STONE         |
| 31       | SHELF STOP TOP       |

**EXPLODED DIAGRAM  
COUNTER TOP PIZZA OVEN  
MODEL: POA1001 R02**

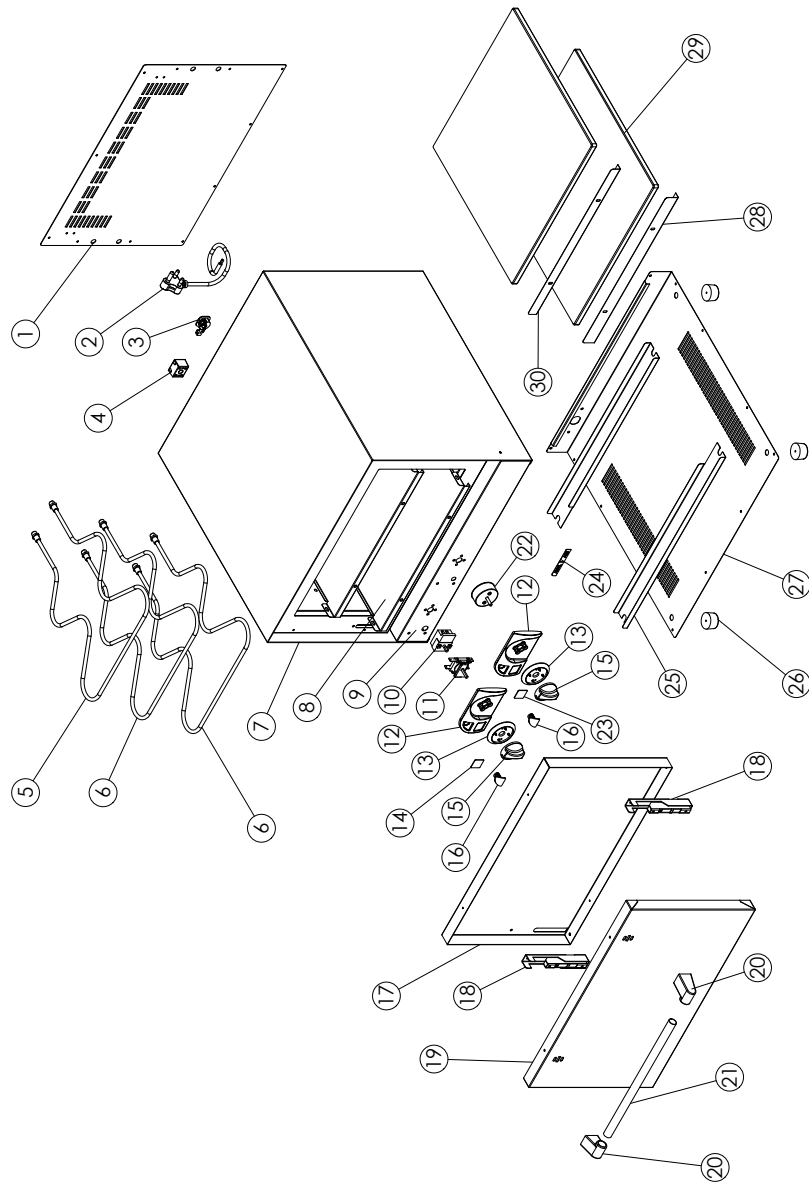

4. After all the electrical connections have been made, the unit requires approximately 2 to 3 hours to burn in. The unit should be in a well ventilated area as odours occur as a result of the burning in of the ceramic decks and the thermal insulation. The unit should be run at 200°C for approximately 1 hour with the door open. Thereafter the door should be closed, the temperature set at 250°C and unit run for a further 2 hours. This will ensure optimum baking results.
5. The unit is provided with a mechanical timer which will give an audible warning at the end of the preset time period.

**SPECIFIC OPERATING INSTRUCTIONS**

1. The temperature range required for pizza baking is usually higher than for general baking. Ideally pizza should cook at approximately 260°C to 300°C
2. The pizza should be allowed to bake until the cheese bubbles and the bottom crust is brown

**BAKING TIPS**

1. Rotation of the pizza during the baking cycle is highly recommended.
2. Always ensure that the pizza crust is fully defrosted before baking.
3. Pizza with a heavy topping will require a longer baking time at a lower temperature.
4. During busy periods increasing the baking temperature helps in maintaining temperature.



## WARNING

### Burn Hazard.

Do not touch hot food, liquid or heating surfaces while equipment is heating or operating

Hot surfaces and food can burn skin. Allow the hot surfaces to cool before handling

## CLEANING

1. Always ensure that the unit is disconnected from the power supply before cleaning.
2. At the end of each grilling cycle clean the inside of the cooking chamber thoroughly
3. Using a mild detergent. The crumb trays are removable to assist cleaning.
4. The spillage on the ceramic decks should be cleaned periodically. Generally this can be scraped out but for hard to clean spillage the following is recommended :
  - Turn the unit to the maximum temperature for 30 minutes.
  - Allow the unit to cool down.
  - Brush the residue from the deck.

**DO NOT USE WATER TO CLEAN THE CERAMIC DECKS !**



THIS APPLIANCE SHOULD NOT BE CLEANED WITH A WATER JET OR IMMERSSED IN WATER. USE ONLY A DAMP CLOTH OR SPONGE DIPPED IN SOAPY WATER. DO NOT USE STEEL-WOOL WHICH WILL MARK THE BRIGHT STAINLESS STEEL FINISH



IT IS ESSENTIAL TO MAKE SURE THAT THE INCOMING VOLTAGE IS THE SAME AS THE RATED VOLTAGE OF THE OF THE UNIT AS FOUND ON THE SERIAL PLATE. THE SERIAL PLATE IS LOCATED AT THE REAR OF THE UNIT ADJACENT TO THE INCOMING CABLE ENTRY.

| MODEL   | DESCRIPTION           | VOLTS (V/Hz) | POWER (W) |
|---------|-----------------------|--------------|-----------|
| POA1001 | PIZZA CONTER TOP OVEN | 230/50       | 2850      |

**WIRING DIAGRAM  
COUNTER TOP PIZZA OVEN  
MODEL CODE: POA1001 R02**

| LEGEND | DESCRIPTION        | PART NUMBER     |
|--------|--------------------|-----------------|
| B1     | CONTROL THERMOSTAT | 1-THERM-POA7001 |
| E1     | 230V/1000W ELEMENT | 5-1000W-POA8001 |
| E2     | 230V/1000W ELEMENT | 5-1000W-POA8001 |
| E3     | 230V/850W ELEMENT  | 5-850W-POA8001  |
| H1     | PILOT LIGHT        | 1-PL-BMA0001    |
| S1     | DOUBLE POLE SWITCH | 1-SW-POA7001    |

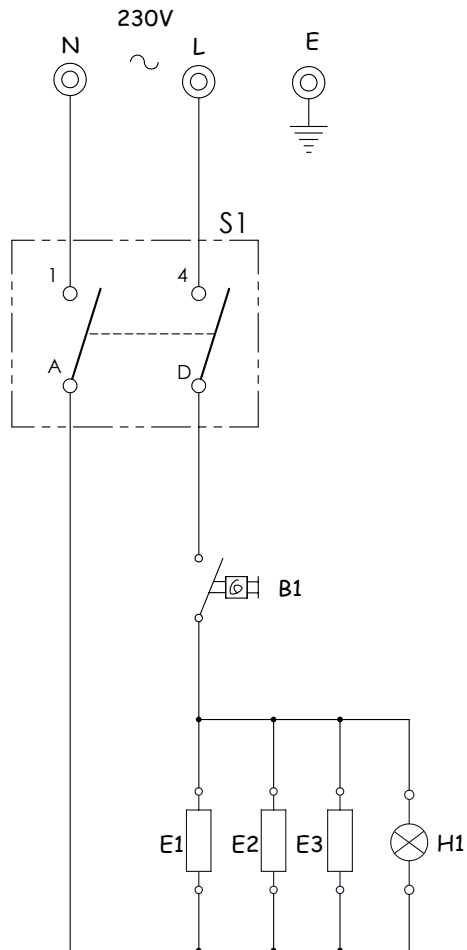

The doors can be removed for cleaning. (Assembly instructions)

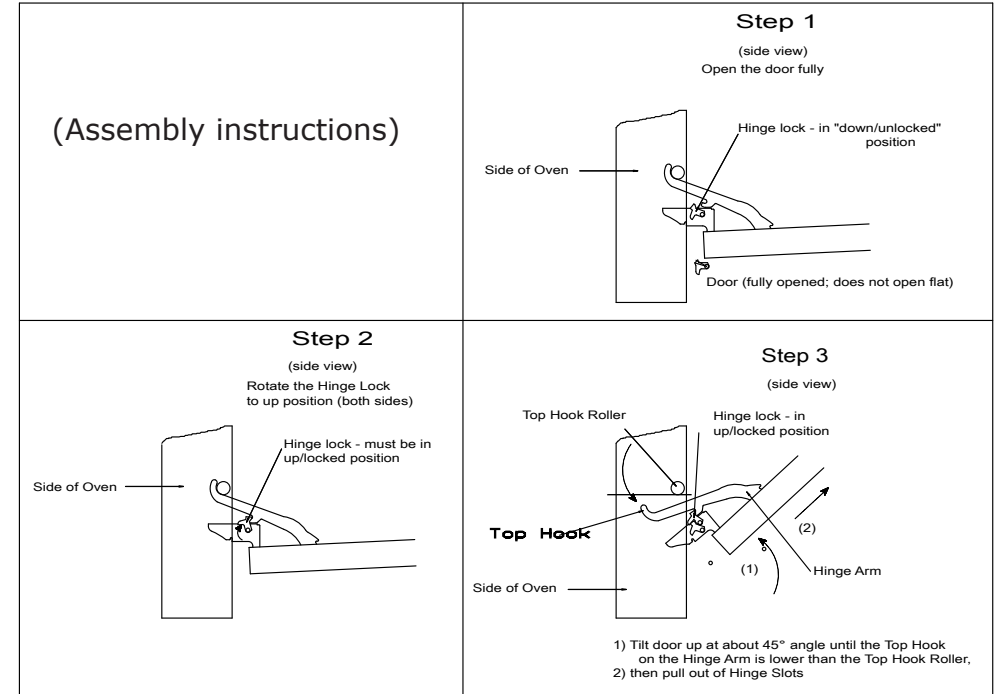



## WARNING

### Electric Shock Hazard.

Keep water and other liquids from entering the inside of the equipment. Liquid inside the equipment could cause an electrical shock

Do not spray water or cleaning products. Liquid could contact the electrical components and cause a short circuit or an electrical shock. Do not use equipment if power cord is damaged or has been modified

## SAFETY

### READ ALL INSTRUCTIONS BEFORE USE. FAILURE TO FOLLOW THESE PRECAUTIONS COULD RESULT IN INJURY TO YOURSELF AND OTHERS

1. When this appliance is to be positioned in close proximity to a wall, partitions, kitchen furniture, decorative finishes, etc. it is recommended that they be made of non-combustible material. If not, they shall be clad with a suitable non-combustible heat insulating material, and the closest attention be paid to fire prevention regulations.
2. Use the appliance on an individual 15A mains outlet only.  
**DO NOT OVERLOAD THE CIRCUIT.**
3. Ensure that the equipment and the power supply cord does not come into contact with hot surfaces.
4. Supervision is necessary when the appliance is used in close proximity to children.
5. If the supply cord is damaged, it must be replaced with a new cord assembly available from the suppliers agent.
6. Use only earthed outlets matching the serial plate voltage.
7. Have equipment installed by a qualified personnel in accordance with local codes and ordinances.
8. Use equipment in a flat level position.
9. Do not operate unattended
10. The equipment may be hot, even though the pilot light is not on.
11. Do not operate if equipment has been damaged or is malfunctioning in any way.
12. These appliances are designed to run only on alternating current (A.C.) **DO NOT CONNECT TO DIRECT CURRENT (D.C)**

### POSITIONING DIAGRAM COUNTER TOP PIZZA OVEN MODEL: POA1001 R02

