

6 BURNER STOVE WITH ELECTRIC OVEN

MANUFACTURING
SINCE 1966



Model: COA4006 - FLAME FAILURE



FEATURES

- Robust Stainless Steel construction with heavy duty door and hinges
- Easily removable cast iron grates
- Powerful stove top burners are easily removable for cleaning
- Removable drip tray beneath stove top to retain spills
- Thermostatically controlled electric oven takes full gastronorm pans
- Powerful oven circulating fan with automatic reversing cycle to promote even baking
- “Cool to touch” die-cast control knobs
- Fitted with chrome plated steel wire shelves
- 0-120 minute timer
- Useful side storage cupboard

NOTE:

- Heavy duty gas products to be connected by approved gas installer



ALL ANVIL EQUIPMENT COMES WITH A TWO YEAR WARRANTY ON COMPONENTS AND DEFECTIVE WORKMANSHIP.

www.anvilworld.com

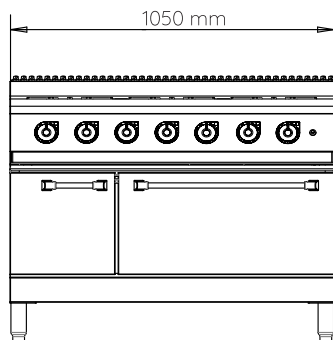
Model: COA4006

SPECIFICATIONS

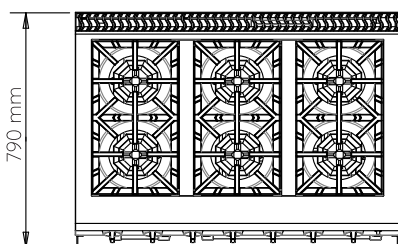
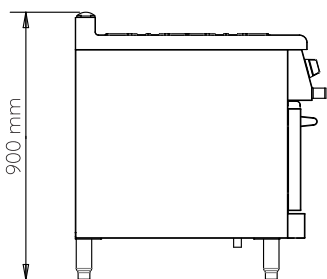
OUTPUT	156 000 BTU
OVEN POWER	4.5kW
VOLTAGE	380V - 50Hz - 3Phase
PACKAGING (W x D x H)	1160 x 900 x 1160 (mm)
UNIT (W x D x H)	1050 x 790 x 900 (mm)
CHAMBER DIMENSIONS	560 x 500 x 285 (mm)
NET WEIGHT	175kg
GROSS WEIGHT	238kg
SHIPPING VOLUME	1.21m ³
GRID SIZE	276 x 527 (mm)(3 off)
REGULATOR	No

AVAILABLE IN
 LPG | Ngas

NOTE

- When viewing the appliance from the front in its usual operating position, the width (W) of the product is the total distance from left to right; the depth (D) of the product is the total distance from the front to the back; the height (H) is the total distance from the bottom of the product to the top. Pictures may vary from actual product.

DISCLAIMER

- Output performance figures quoted are dependent on various factors. Anvil reserves the right, without notice, to make changes and revisions to product specifications, materials and design, when we believe it will provide better performance, durability, and efficiency. Unit measurements may vary depending on point of reference.

ALL ANVIL EQUIPMENT COMES WITH A TWO YEAR WARRANTY ON COMPONENTS AND DEFECTIVE WORKMANSHIP.
www.anvilworld.com