



ANVIL

Installation, Operation and Care Manual



SCAN ME
TO GO TO
WARRANTY
REGISTRATION

MANUFACTURING
SINCE 1966

4-INS-CDA2001

THE CHEFS COMPANION

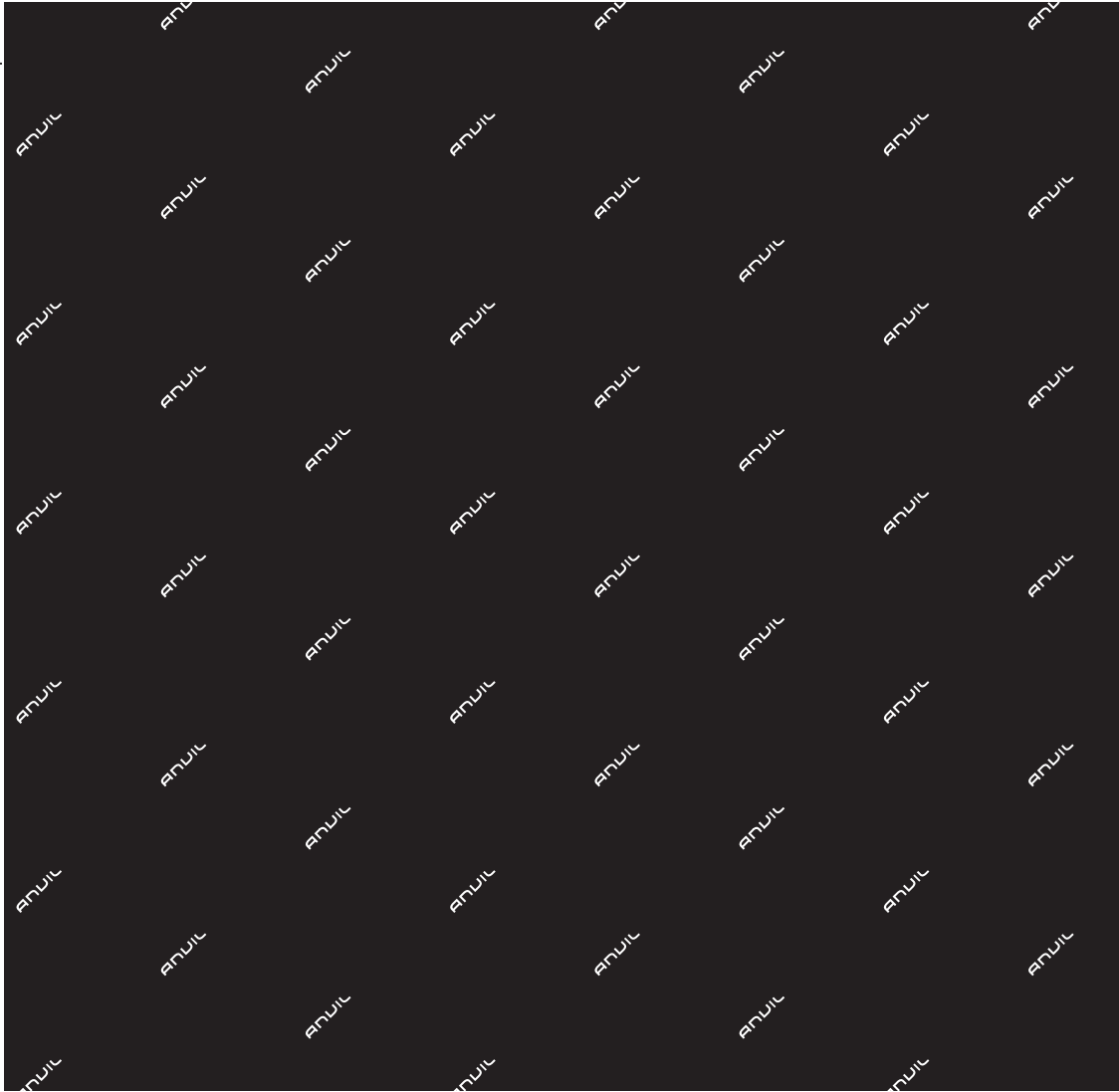

THE CHEFS COMPANION



THANK YOU FOR PURCHASING AN ANVIL PRODUCT!



REGISTER ONLINE TODAY

Register your warranty on-line at www.anvilworld.com today and learn how to get the best out of your Anvil product, tips to care for your Anvil product for long lasting performance, exciting recipes and more.

NO WEB ACCESS?

If you do not have access to the Web, register by completing this form and faxing it to the Anvil head office in South Africa. Fax: +27 11 474 1630

ONLY COMPLETE IF YOU DO NOT HAVE WEB ACCESS

Company _____

Name _____

Surname _____

Telephone _____

Cellphone _____

Email Address _____

Country _____

Postal address _____

Anvil products purchased _____

Code (see box label) _____

Serial number (see back of machine) _____

INTENDED USE

- Full-Service restaurant
- Coffee Shop / Deli
- Fast Food Outlet
- Hotel
- Bed & Breakfast
- School Cafeteria

- Institutional Cafeteria
- Corporate Catering
- Private Use
- Franchisor
- Convenience Store
- Other

 ALL ANVIL EQUIPMENT COMES WITH A TWO YEAR WARRANTY ON COMPONENTS AND DEFECTIVE WORKMANSHIP.

www.anvilworld.com

LIMITED WARRANTY

All equipment which is sold under ANVIL trademark and used for commercial purposes is warranted against defects in materials and workmanship. The warranty runs for two years from the date of original installation and is for the benefit of the original purchaser only. All other Warranties ,expressed or implied , statutory or otherwise, including without limitations any implied Warranty of Merchantability or fitness for purpose are excluded .The Seller shall in no event be liable for direct,indirect or consequential damages in connection with ANVIL commercial products.

The Sellers obligation under this Warranty is limited to the repair of defects without charge. Defective units must be taken or shipped,transportation charges prepaid,to ANVIL.

This Warranty is not effective if damage occurs because of accident,carelessness,improper installation,lack of proper set-up,supervision when required or if the equipment is installed or operated in any manner contrary to the installation and operating instructions. In these cases,repairs will be made at a reasonable cost. Work performed by unauthorized personnel or unauthorized service agencies using non Anvil spares voids this Warranty.



NB:

REGISTER ON-LINE TODAY

Register your warranty on-line now at www.anvilworld.com

NO WEB ACCESS

If you do not have access to the Web. Kindly register by completing the warranty registration form and fax it to the ANVIL office in the country of purchase.

Failure to do so will invalidate your warranty.

FLOOR STANDING CHIP DUMP

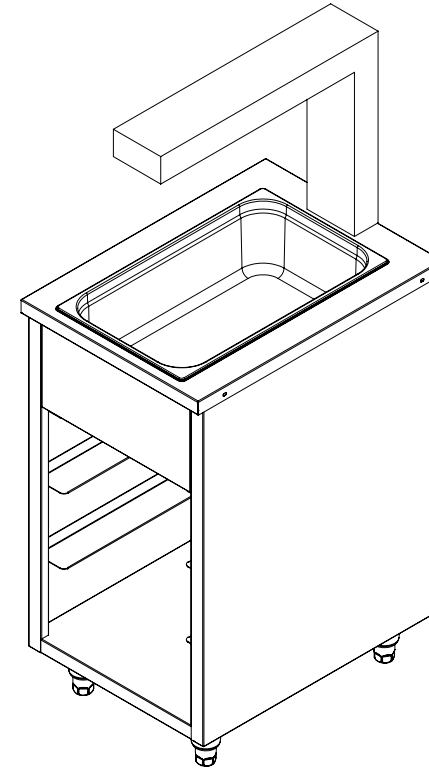

**INSTALLATION OPERATION AND CARE OF
FLOOR STANDING CHIP DUMP
MODEL: CDA2001 R0**

UNPACKING

Unpack the product and check for any damage incurred during transit. This should be reported to the responsible carrier, railway or postal authority, and a request for a damage report should be made.



THESE INSTRUCTIONS MUST BE FOLLOWED FOR US TO GUARANTEE OUR FULL SUPPORT OF YOUR CLAIM FOR PROTECTING AGAINST LOSS FROM CONCEALED DAMAGE. THE FORM FOR FILING SUCH A CLAIM WILL BE PROVIDED BY THE CARRIER.

GENERAL INSTALLATION

1. Ensure that the unit is positioned on a level counter at least 150mm away from a wall or another appliance to allow for sufficient ventilation of the unit and also reducing the potential of a fire hazard.
2. Plug unit into an earthed 240V AC supply

OPERATING INSTRUCTIONS

1. Plug appliance to mains outlet and turn switch on.
2. Turn on main power switch. The illuminating lamp will burn continuously.
3. The unit will warm up to operating temperature in approximately 15 minutes.
4. Avoid piling cooked chips more than two layers on a chip dump - Chips that are piled too high will steam themselves and go soggy very quickly.
5. Keep hold time to a minimum - Keep regular chips under the chip warmer for no more than 7 minutes.

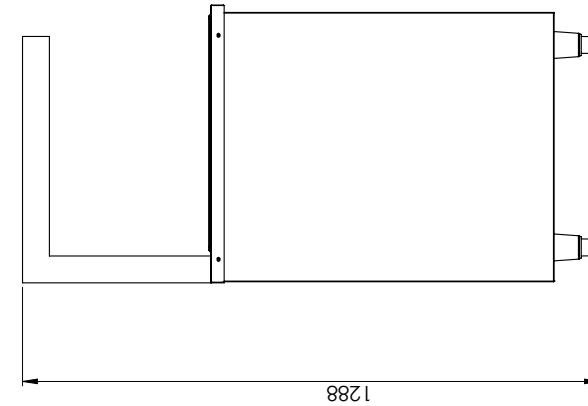

Positioning Diagram

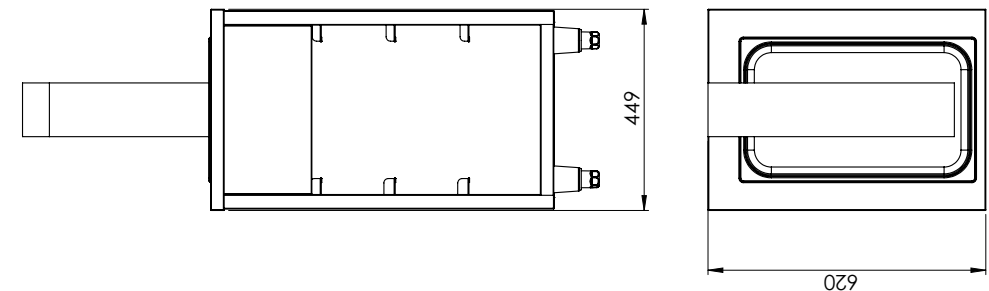

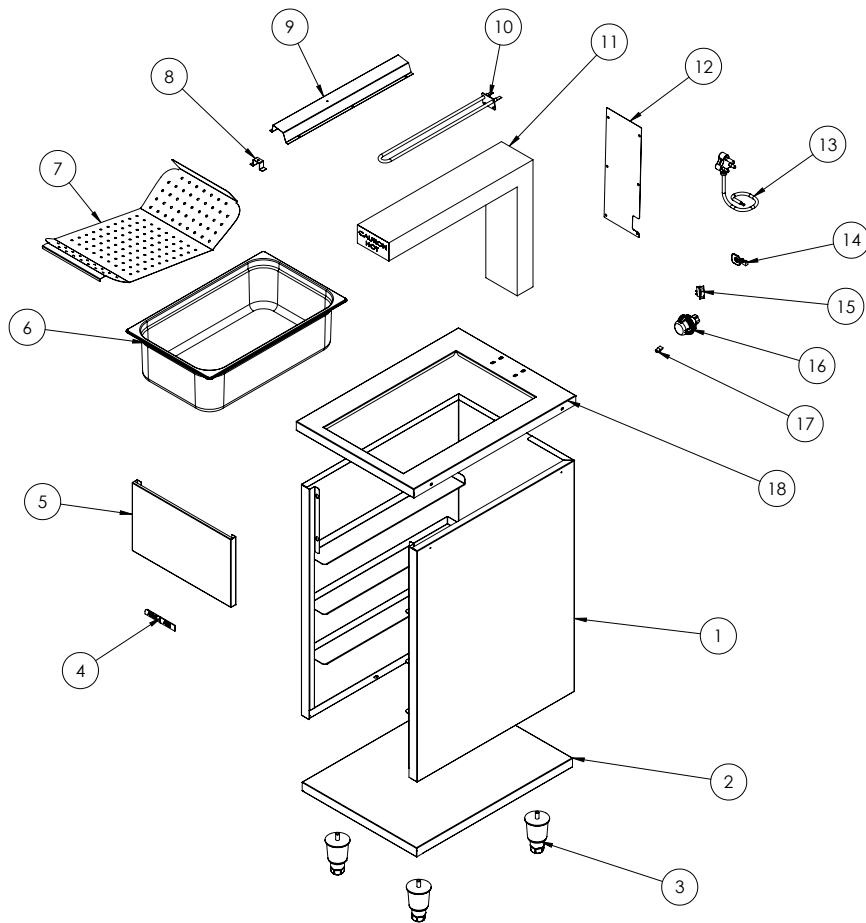

PART No.	DESCRIPTION
1	BODY
2	BASE
3	ADJUSTABLE LEG
4	ANVIL BADGE
5	FRONT PANEL
6	CHIPDUMP INSERT
7	SCOOP DRIP TUBE
8	ELEMENT SUPPORT BRACKET
9	ELEMENT REFLECTOR
10	CHIPDUMP INCOLLOY ELEMENT
11	HEAD ASSEMBLY
12	REAR COVER
13	POWER CORD
14	CABLE GRIP
15	NON-ILLUMINATED ROCKER SWITCH
16	LIGHT BULB HOLDER
17	LIGHT BULB
18	TOP PANEL



WARNING

Electric Shock Hazard.

Keep water and other liquids from entering the inside of the equipment. Liquid inside the equipment could cause an electrical shock.

Do not spray water or cleaning products. Liquid could contact the electrical components and cause a short circuit or an electrical shock. Do not use equipment if power cord is damaged or has been modified.

SAFETY

READ ALL INSTRUCTIONS BEFORE USE. FAILURE TO FOLLOW THESE PRECAUTIONS COULD RESULT IN INJURY TO YOURSELF AND OTHERS

- When this appliance is to be positioned in close proximity to walls, partitions, kitchen furniture, decorative finishes, etc. it is recommended that they be made of non-combustible material. If not, they shall be clad with a suitable non-combustible heat insulating material, and the closest attention be paid to fire prevention regulations.
- Use the multifunction warmer on an individual 15A mains outlet only. **DO NOT OVERLOAD THE CIRCUIT.**
- Ensure that the equipment and the power supply cord does not come into contact with hot surfaces.
- Supervision is necessary when the appliance is used in close proximity to children.
- If the supply cord is damaged, it must be replaced with a new cord assembly available from the suppliers agent. The cord shall be an oil resistant sheathed flexible cable not lighter than ordinary polychloroprene or equivalent synthetic elastomer - sheathed cord (code designation 60245 IEC 57)
- Use only earthed outlets matching the serial plate voltage.
- Have equipment installed by a qualified personnel in accordance with local codes and ordinances.
- Use equipment in a flat level position.
- Do not operate unattended
- The equipment may be hot, even though the pilot light is not on.
- Do not operate if equipment has been damaged or is malfunctioning in any way.
- These units are designed to run only on alternating current (A.C.) **DO NOT CONNECT TO DIRECT CURRENT (D.C)**



WARNING

Burn Hazard.

Do not touch hot food, liquid or heating surfaces while equipment is heating or operating

Hot surfaces and food can burn skin. Allow the hot surfaces to cool before handling

CLEANING

1. Always ensure that the unit is disconnected from the main power supply before cleaning.
2. This unit should not be cleaned with a water jet or immersed in water. Use only a damp cloth or sponge dipped in soapy water.
3. Wipe off the unit with a dry cloth and wait at least a half an hour before re-connecting to the main power outlet.



CLEAN THE STAINLESS STEEL PARTS WITH WATER AND SOAP. AVOID THE USE OF DETERGENTS CONTAINING ABRASIVE SUBSTANCES. ALWAYS RINSE WELL AND DRY CAREFULLY AFTER CLEANING. DO NOT USE PRODUCTS CONTAINING AGGRESSIVE CHEMICALS, ACIDS OR PRODUCTS WITH CHLORINE TO CLEAN THE STAINLESS STEEL EVEN IF DILUTED

ELECTRICAL CONNECTION INFORMATION

MODEL	DESCRIPTION	VOLTS (V /Hz)	POWER (W)
CDA2001	CHIP WARMER	230/50	1000



IT IS ESSENTIAL TO MAKE SURE THAT THE INCOMING VOLTAGE IS THE SAME AS THE RATED VOLTAGE OF THE OF THE UNIT AS FOUND ON THE SERIAL PLATE. THE SERIAL PLATE IS LOCATED AT THE REAR OF THE UNIT ADJACENT TO THE INCOMING CABLE ENTRY.

WIRING DIAGRAM

MODEL: CHIP WARMER

MODEL CODE: CDA2001

LEGEND	DESCRIPTION	PART NUMBER
S1	NON ULLUMINATED ROCKER SWITCH	1-RS-NI
EL	ELEMENT 1000W/230V	5-1000W-CD
L	OVEN LIGHT	1-OVEN-LH

