

# ICE CREAM FRIDGE 900mm COUNTERTOP

MANUFACTURING  
SINCE 1966



**Model: ICF0900**



## FEATURES

- Perfect for display of ice cream at point of sale
- Automatic defrost
- Temperature range -15°C to -20°C
- High quality digital temperature controller
- Heated Tempered glass to prevent condensation build up
- Low pressure hermetic compressor R404 gas
- Table top mounting
- Grade 304 Stainless Steel interior

### NOTE:

- 5 x Polycarbonate 5ℓ Inserts Included



ALL ANVIL EQUIPMENT COMES WITH A TWO YEAR WARRANTY ON COMPONENTS AND DEFECTIVE WORKMANSHIP.

[www.anvilworld.com](http://www.anvilworld.com)

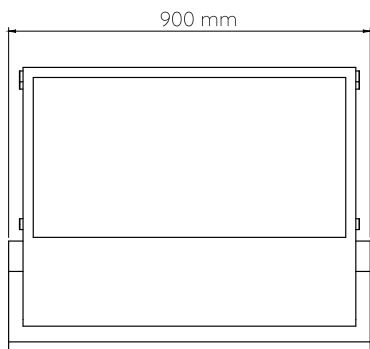
**Model: ICF0900**

**SPECIFICATIONS**

POWER	0.5kW
VOLTAGE	230V - 50Hz
PACKAGING (W x D x H)	1010 x 640 x 940 (mm)
UNIT (W x D x H)	900 x 540 x 790 (mm)
NET WEIGHT	108kg
GROSS WEIGHT	125kg
SHIPPING VOLUME	0.61m <sup>3</sup>
TEMPERATURE	-15°C to -20°C
CAPACITY	5 x 5ℓ pans

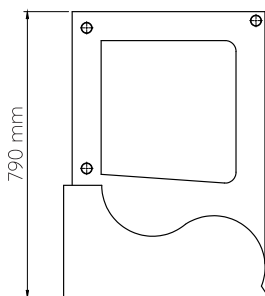
AVAILABLE IN

 120V/60Hz

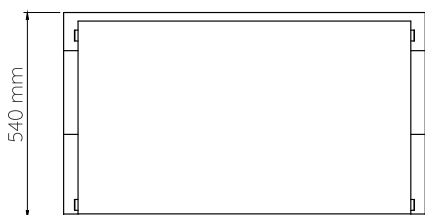
**OPTIONAL EXTRAS**
**INSERTS**

CODE	DESCRIPTION
XICF0001	Ice Cream Freezer Insert

**NOTE**

- When viewing the appliance from the front in its usual operating position, the width (W) of the product is the total distance from left to right; the depth (D) of the product is the total distance from the front to the back; the height (H) is the total distance from the bottom of the product to the top. Pictures may vary from actual product.

**DISCLAIMER**

- Output performance figures quoted are dependent on various factors. Anvil reserves the right, without notice, to make changes and revisions to product specifications, materials and design, when we believe it will provide better performance, durability, and efficiency. Unit measurements may vary depending on point of reference.



**ALL ANVIL EQUIPMENT COMES WITH A TWO YEAR WARRANTY ON COMPONENTS AND DEFECTIVE WORKMANSHIP.**

[www.anvilworld.com](http://www.anvilworld.com)