



ANVIL

Installation, Operation and Care Manual



SCAN ME
TO GO TO
WARRANTY
REGISTRATION

MANUFACTURING
SINCE 1966

4-INS-CBL0300

THE CHEFS COMPANION

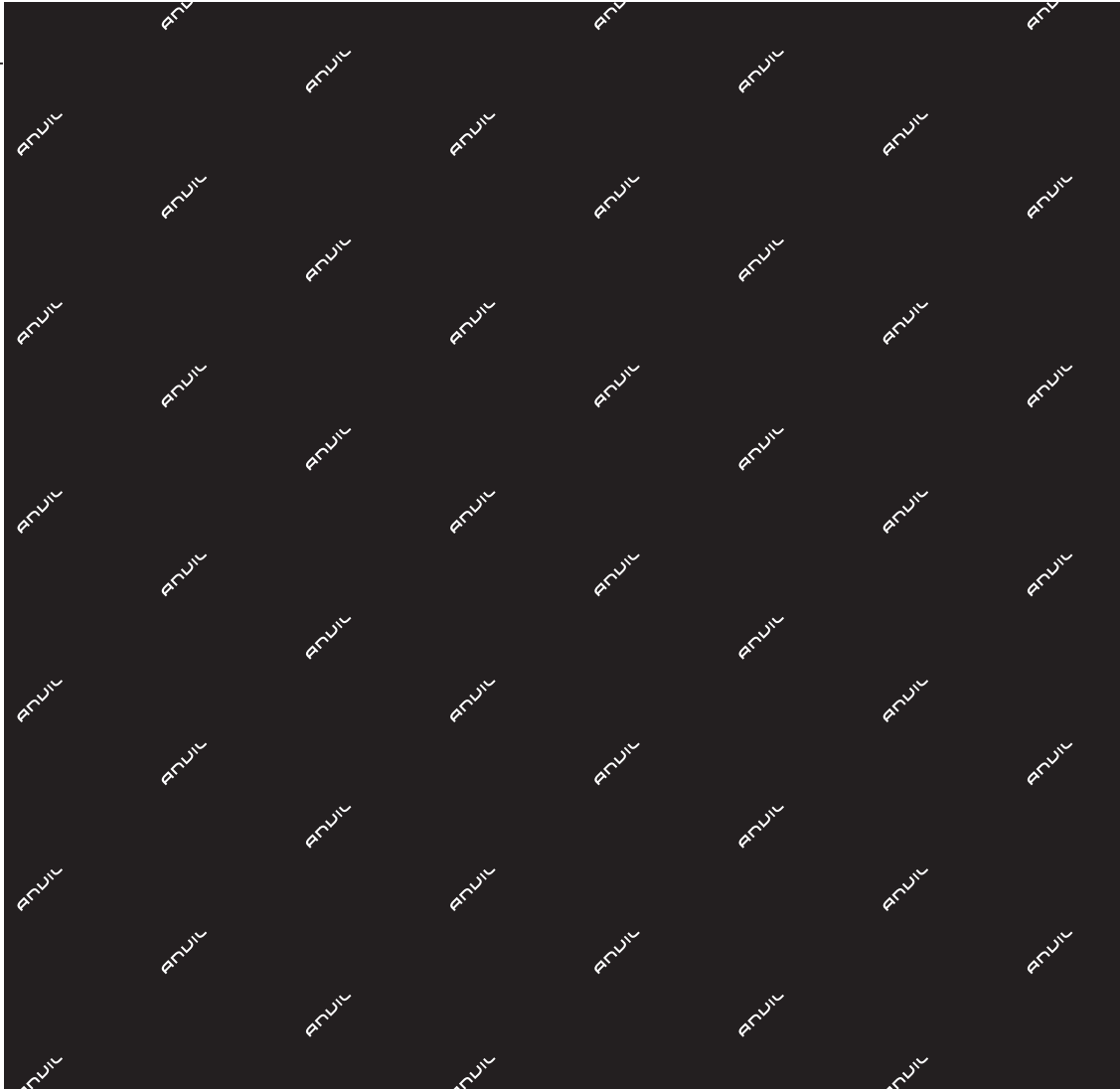

THE CHEFS COMPANION



THANK YOU FOR PURCHASING AN ANVIL PRODUCT!

REGISTER ONLINE TODAY

Register your warranty on-line at www.anvilworld.com today and learn how to get the best out of your Anvil product, tips to care for your Anvil product for long lasting performance, exciting recipes and more.

NO WEB ACCESS?

If you do not have access to the Web, register by completing this form and faxing it to the Anvil head office in South Africa. Fax: +27 11 474 1630

ONLY COMPLETE IF YOU DO NOT HAVE WEB ACCESS

Company _____

Name _____

Surname _____

Telephone _____

Cellphone _____

Email Address _____

Country _____

Postal address _____

Anvil products purchased _____

Code (see box label) _____

Serial number (see back of machine) _____

INTENDED USE

- | | |
|--|--|
| <input type="checkbox"/> Full-Service restaurant | <input type="checkbox"/> Institutional Cafeteria |
| <input type="checkbox"/> Coffee Shop / Deli | <input type="checkbox"/> Corporate Catering |
| <input type="checkbox"/> Fast Food Outlet | <input type="checkbox"/> Private Use |
| <input type="checkbox"/> Hotel | <input type="checkbox"/> Franchisor |
| <input type="checkbox"/> Bed & Breakfast | <input type="checkbox"/> Convenience Store |
| <input type="checkbox"/> School Cafeteria | <input type="checkbox"/> Other |

 ALL ANVIL EQUIPMENT COMES WITH A TWO YEAR WARRANTY ON COMPONENTS AND DEFECTIVE WORKMANSHIP.

www.anvilworld.com

LIMITED WARRANTY

All equipment which is sold under ANVIL trademark and used for commercial purposes is warranted against defects in materials and workmanship. The warranty runs for two years from the date of original installation and is for the benefit of the original purchaser only. All other Warranties ,expressed or implied , statutory or otherwise, including without limitations any implied Warranty of Merchantability or fitness for purpose are excluded .The Seller shall in no event be liable for direct,indirect or consequential damages in connection with ANVIL commercial products.

The Sellers obligation under this Warranty is limited to the repair of defects without charge. Defective units must be taken or shipped,transportation charges prepaid,to ANVIL.

This Warranty is not effective if damage occurs because of accident,carelessness,improper installation,lack of proper set-up,supervision when required or if the equipment is installed or operated in any manner contrary to the installation and operating instructions. In these cases,repairs will be made at a reasonable cost. Work performed by unauthorized personnel or unauthorized service agencies using non Anvil spares voids this Warranty.



NB:

REGISTER ON-LINE TODAY

Register your warranty on-line now at www.anvilworld.com

NO WEB ACCESS

If you do not have access to the Web. Kindly register by completing the warranty registration form and fax it to the ANVIL office in the country of purchase.

Failure to do so will invalidate your warranty.

GAS GRILLERS AND GAS RADIANT CHARBROILERS PILOT BURNER MODELS

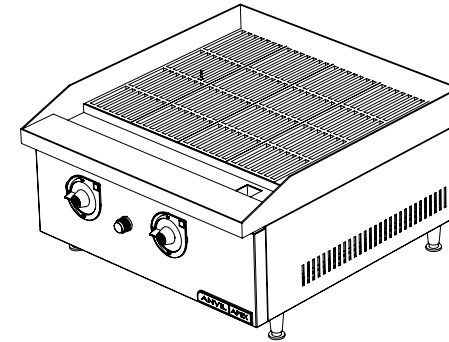

INSTALLATION OPERATION AND CARE OF GAS GRILLERS AND GAS RADIANT CHARBROILERS

**MODELS: CBF0300 / CBF0400 / CBF0600
CBF0900 / CBF1200 / CBF1500
CBL0300 / CBL0400 / CBL0600
CBL0900 / CBL1200 / CBL1500**

UNPACKING

Unpack the product and check for any damage incurred during transit. This should be reported to the responsible carrier, railway or postal authority, and a request for a damage report should be made.



THESE INSTRUCTIONS MUST BE FOLLOWED FOR US TO GUARANTEE OUR FULL SUPPORT OF YOUR CLAIM FOR PROTECTING AGAINST LOSS FROM CONCEALED DAMAGE. THE FORM FOR FILING SUCH A CLAIM WILL BE PROVIDED BY THE CARRIER.

These appliances are intended for use with LPG at a pressure of 2.8kPa. Regulators used with this appliance must comply to SANS 1237 and be approved by the LPGASA. Only regulators certified for operation at 2.8kPa must be used on these appliances.

These appliances may be converted by qualified personnel to be used for Natural Gas with a suitable regulator operating at 1.25kPa.

GENERAL INSTALLATION AND OPERATION INSTRUCTIONS



ENSURE THAT THE ADJUSTABLE SUPPORT FEET PROVIDED ARE ASSEMBLED ONTO THE UNIT BEFORE COMMENCING OPERATION

1. This appliance should only be used in a WELL – VENTILATED ROOM. Adequate ventilation allows for the removal of the products of combustion and allows the entry of replacement air.
2. This appliance has a factory set fixed primary air intake and no adjustment is necessary. No adjustments to jets or air intakes should be undertaken unless carried out by a factory approved agent.
3. The Installation of appliances may only be carried out by a registered installer and such installations shall comply with the local requirements
4. Make sure that all connections are gas tight by brushing with a soapy water or liquid detergent (a gas leak will form bubbles). If bubbles form, close cylinder valve and hand tighten all fittings again. IF BUBBLES STILL FORM, DO NOT USE THE APPLIANCE. Have a dealer check the appliance.
5. The units are equipped with standing pilots, and should be lit immediately after the gas is turned on. Light pilots as follow:

GAS RADIANT CHARBROILER MODEL CODE: CBL0900

Part No.	Stock Code	Description
1	7-RAD-GRID	GRID
2		SPLASH GUARD ASSEMBLY
3		FIRE WALL
4	7-BURNER-CBF-1	BURNER
5		LEFT SIDE PANEL
6	7-MAN-GGR0900	MANIFOLD
7		CROSS BRACKET TOP AND BOTTOM
8	7-SP-GGR0400	SPARK PLUG WITH WIRE
9		DRIP TRAY
10		FRONT FIRE WALL
11	7-JET-GGR0400	JET
12	7-ELB-GGR0400	ELBOW
13	7-VAL-FTG0300	CONTROL VALVE
14	7-IS-GGR0400	IGNITION SWITCH
15		FRONT PANEL
16	4-BEZ-COA3004	GAS CONTROL BEZEL
17	3-KNOB-LEAVER	LEVER KNOB
18	4-BEZ-BADGE	BADGE BEZEL
19	4-DL-L-APEX	DOMED LABEL APEX
20	7-FOOT-FTA7016	ADJUSTABLE FOOT
21		RIGHT SIDE PANEL
22	7-TC-GGR0400	PREMIER GAS RANGE THERMOCOUPLE
23		BURNER SURPORT BRACKET
24		BURNER SURPORT BRACE
25		GRATE ADJUSTMENT SUPPORT
26		RADIANT COVER
27		CROSS PIECE RADIANT COVER
28		BACK PANEL

EXPLODED DIAGRAM GAS RADIANT CHARBROILER CBL0900

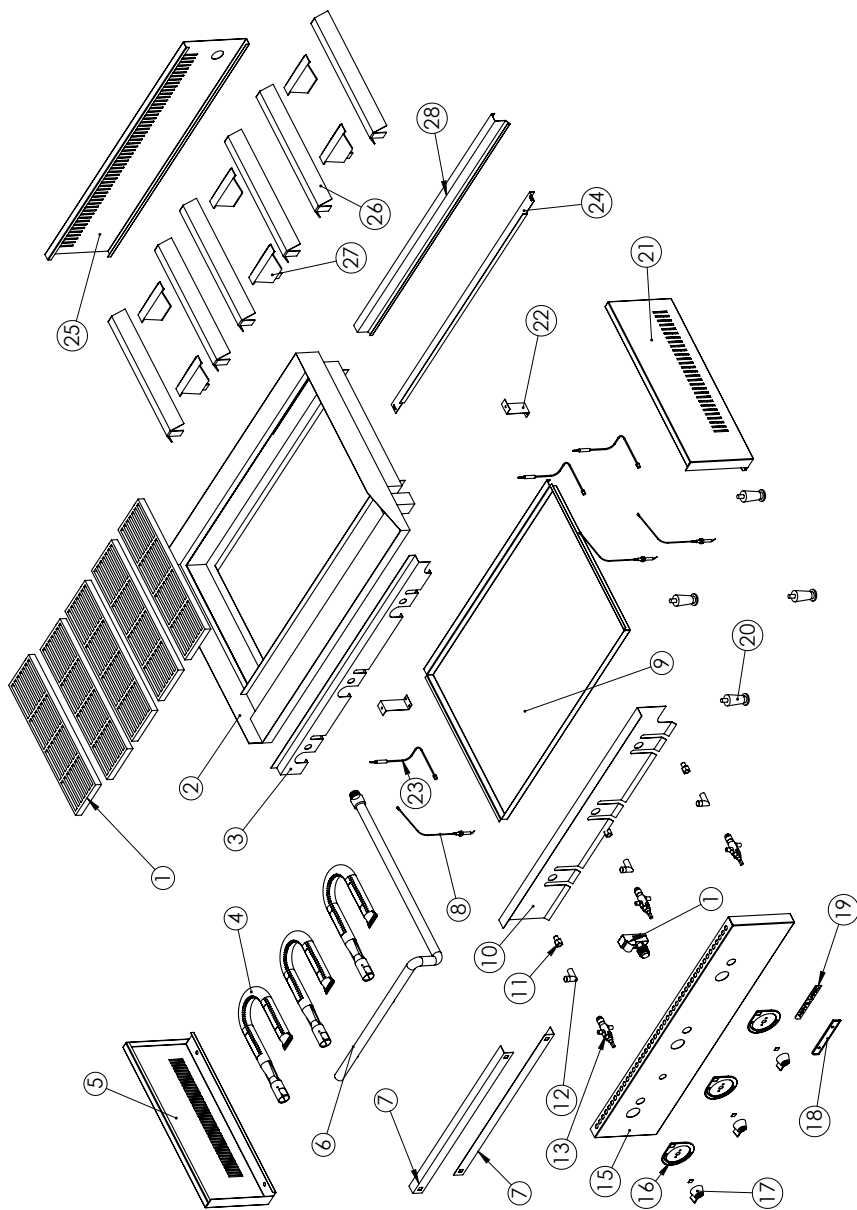

THIS APPLIANCE MUST NOT BE USED IN BASEMENTS OR IN ROOMS LESS THAN 15 CUBIC METRES IN VOLUME. (TYPICALLY 2.6M SQUARE)

- Turn off main valve to unit and wait 5 minutes to clear gas.
 - Turn off all control knobs .
 - Turn on main valve and light all pilots.
 - The pilot burner must be lit , at the end of the tube. Hold an ignition source (6 " fire lighter) Through the opening in the front panel at the pilot tube. When the flame is established remove ignition source.
6. The pilot flame on the griddle has been adjusted at the factory. Adjust pilot flames as small as possible, but high enough to light the burner immediately when burner valve is turned to the 'High' setting. Access to the pilot flame adjustment screw is obtained by removing the front panel.
 7. When igniting the required burner, depress the knob of the burner and turn to the 'HIGH' position. Thereafter set the burner control to the desired heat between 'LOW' and 'HIGH' on the scale.
 8. In the event of burn back, where the flame burns back and ignites at the jet, immediately turn off the gas supply by first closing the control valve on the gas cylinder and then the appliance valve. After the flame is extinguished, remove the gas regulator and check the condition of its seal, replace the seal if in doubt. Re-light the appliance as described in Section 5 and 6 above. Should the flame light back persistently, return the product to your authorized ANVIL repair agent.
 9. To re-light the burner, follow the procedure as in paragraph 5 and 6 above.
 10. Before cooking on the appliance for the first time, turn the controls to the maximum heat and allow the griller to BURN IN for approximately 20 minutes. You will notice smoke appearing due to the protective coating burning off. THIS IS NORMAL.
 11. After the burn-in time has elapsed, turn the control valve knob down to the required operating setting.
 12. To switch off this appliance, turn the control knobs to the 'OFF' position and close the valve on the gas cylinder by turning the hand wheel in a CLOCK WISE direction.
 12. This unit is provided with adjustable levelling feet to ensure that the level of the top can be adjusted to allow the excess fat and grease to drain easily into the drip tray.

SPECIFIC INSTRUCTIONS FLAT TOP GRILLERS

1. Turn the unit on and preheat on 'HIGH' position before attempting to grill. Adjust the valve to obtain the desired heat.
2. The fat tray is located at the bottom of the unit, and is easily removed from the front of the unit. The fat tray catches the grease and should be emptied on a regular basis.
3. Air for combustion enters from the bottom of the unit. Do not obstruct this area.

SPECIFIC INSTRUCTIONS GAS RADIANT CHARBROILER

1. Turn the valves on and preheat the unit on 'HIGH' before attempting to grill.
2. It is recommended that the grate be set at the full tilt position to start with. This position allows the grease to run down the grate into the fat tray reducing flare ups.
3. Check water pans regularly and add a sufficient amount of water. Hot water vapors rising from the water pan and through the combustion chamber help to reduce flare ups.
4. The grate can be tilted by using the bracket located at the rear of the unit. It is possible using this arrangement to have a high heat or searing section while having a low heat finishing or holding section. The gas valves can be set accordingly.
5. All radiant charbroilers can be readily converted to lava rock versions by using the conversion kit as described in the description of models. The radiant cover over the burner must be removed and replaced with the cast iron grate and lava rocks.

**GAS RADIANT CHARBROILER
MODEL CODE: CBL0600**

Part No.	Stock Code	Description
1	7-RAD-GRID	GRID
2		SPLASH GUARD ASSEMBLY
3		FIRE WALL
4	7-BURNER-CBF-1	BURNER
5		LEFT SIDE PANEL
6	7-MAN-GGR0900	MANIFOLD
7		CROSS BRACKET TOP AND BOTTOM
8	7-SP-GGR0400	SPARK PLUG WITH WIRE
9		DRIP TRAY
10		FRONT FIRE WALL
11	7-JET-GGR0400	JET
12	7-ELB-GGR0400	ELBOW
13	7-VAL-FTG0300	CONTROL VALVE
14	7-IS-GGR0400	IGNITION SWITCH
15		FRONT PANEL
16	4-BEZ-COA3004	GAS CONTROL BEZEL
17	3-KNOB-LEAVER	LEVER KNOB
18	4-BEZ-BADGE	BADGE BEZEL
19	4-DL-L-APEX	DOMED LABEL APEX
20	7-FOOT-FTA7016	ADJUSTABLE FOOT
21		RIGHT SIDE PANEL
22	7-TC-GGR0400	PREMIER GAS RANGE THERMOCOUPLE
23		BURNER SURPORT BRACKET
24		BURNER SURPORT BRACE
25		GRATE ADJUSTMENT SUPPORT
26		RADIANT COVER
27		CROSS PIECE RADIANT COVER
28		BACK PANEL

EXPLODED DIAGRAM GAS RADIANT CHARBROILER CBL0600

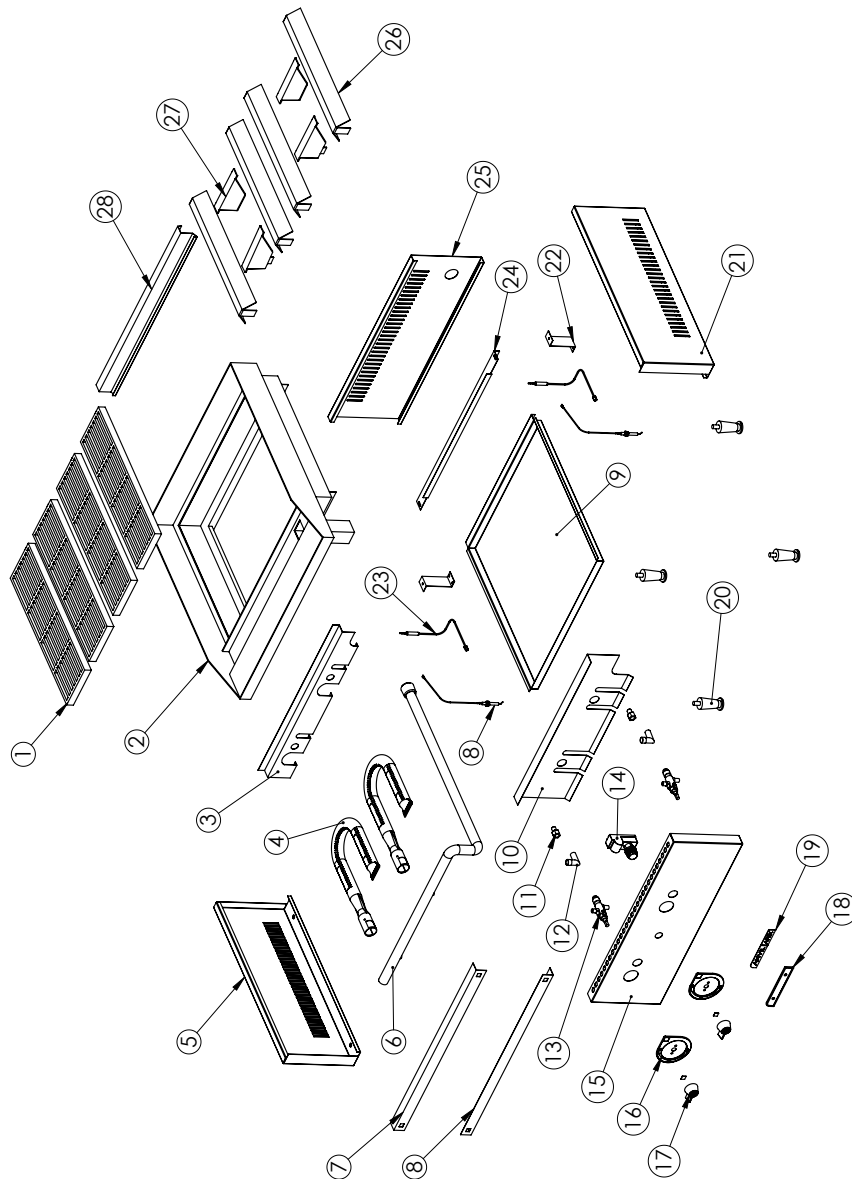

WARNING

Burn Hazard.

Do not touch hot food, liquid or heating surfaces while equipment is heating or operating

Hot surfaces and food can burn skin. Allow the hot surfaces to cool before handling

DAILY CLEANING

1. Remove large pieces of food residue and carefully scrape spill-over from the drip tray located below the unit.
2. Wash all exterior surfaces with hot soapy water solution. DO NOT use harsh abrasives on any portion of the stainless or coated surfaces.
3. Cast iron grates should be scraped with a wire brush frequently, and periodically soaked in a hot water solution to remove grease from the pores of the cast iron. Never expose the grates to extreme heat for the purpose of burning off excess fat. This practice will shorten the life of the grate.
4. In the case of the lava rock units this should be turned over approximately once a week depending on the amount of cooking and type of food prepared.. High heat will effectively clean and burn off grease. A loosely placed layer of rock will serve as an effective base. About one half layer of rock should be strategically added to compensate for hot spots.
5. Over-filling the radiant charbroiler will obstruct proper airflow creating poor combustion, an uneven heating pattern, and will ultimately shorten the useful life of the cast iron bottom grates and burners. As the lava rock disintegrates over time, rock smaller than a golf ball \pm 50mm diameter should be removed and replaced with new larger rock.



THIS APPLIANCE SHOULD NOT BE CLEANED WITH A WATER JET OR IMMERSED IN WATER.

MAINTENANCE

There are no predetermined maintenance intervals for this appliance however the following should be observed.

1. Inspect hoses and replace if they are not in order, before using the appliance as cracked and perished hoses can be dangerous replace if necessary with hoses as detailed in point 5.
2. Allow the appliance to cool sufficiently before attempting any maintenance.
3. The appliance is fitted with a jet to regulate the correct amount of gas. The small hole in the jet may become blocked, resulting in a small flame or no flame on the burner. To clean, unscrew it from the appliance Clean the jet by blowing the hexagon end, or by using a jet cleaner. Do NOT attempt to clean the jet with a sharp object, as this will damage the very small jet aperture and cause the stove to malfunction. If the jet still does not function, replace it with a new jet of the correct size. To re-assemble, reverse the above procedures. The same procedure applies if the pilot burner jet becomes blocked
4. Check that the flexible hose is completely connected over the nozzles at each end of the tubing and that it is held firmly in place by hose clamps. Examine the flexible hose regularly, at least each time the gas cylinder is changed and ask your dealer to fit a new LPG hose if it becomes perished, worn or damaged.
5. Only LPG hose that complies with SANS 1156-2 or BS 3212 may be used with this appliance.

6. Trouble Shooting

- A normal flame is blue and may have an orange or yellow tip. If the flame is completely yellow, it may be that the jet is not securely fitted. Re-tighten to give a gas tight seal. An over-filled gas cylinder can also cause large yellow flames. Cylinder should be returned to filling station and checked by weight.
- Check that the primary air supply apertures in the burners are clear and free of obstructions.
- If the flame power drops or the gas will not light, check that the gas cylinder still contains gas (shake to hear the noise made by the liquid). If there is still gas, the jet might have become blocked or partially blocked.
- If you suspect a blocked jet, follow the instruction in Section 3 above.

GAS RADIANT CHARBROILER MODEL CODE: CBL0400

Part No.	Stock Code	Description
1	7-RAD-GRID	GRID
2		SPLASH GUARD ASSEMBLY
3		FIRE WALL
4	7-BURNER-CBF-1	BURNER
5		LEFT SIDE PANEL
6	7-MAN-GGR0900	MANIFOLD
7		CROSS BRACKET TOP AND BOTTOM
8	7-SP-GGR0400	SPARK PLUG WITH WIRE
9		DRIP TRAY
10		FRONT FIRE WALL
11	7-JET-GGR0400	JET
12	7-ELB-GGR0400	ELBOW
13	7-VAL-FTG0300	CONTROL VALVE
14	7-IS-GGR0400	IGNITION SWITCH
15		FRONT PANEL
16	4-BEZ-COA3004	GAS CONTROL BEZEL
17	3-KNOB-LEAVER	LEVER KNOB
18	4-BEZ-BADGE	BADGE BEZEL
19	4-DL-L-APEX	DOMED LABEL APEX
20	7-FOOT-FTA7016	ADJUSTABLE FOOT
21		RIGHT SIDE PANEL
22	7-TC-GGR0400	PREMIER GAS RANGE THERMOCOUPLE
23		BURNER SURPORT BRACKET
24		BURNER SURPORT BRACE
25		GRATE ADJUSTMENT SUPPORT
26		RADIANT COVER
27		CROSS PIECE RADIANT COVER
28		BACK PANEL

EXPLODED DIAGRAM GAS RADIANT CHARBROILER CBL0400

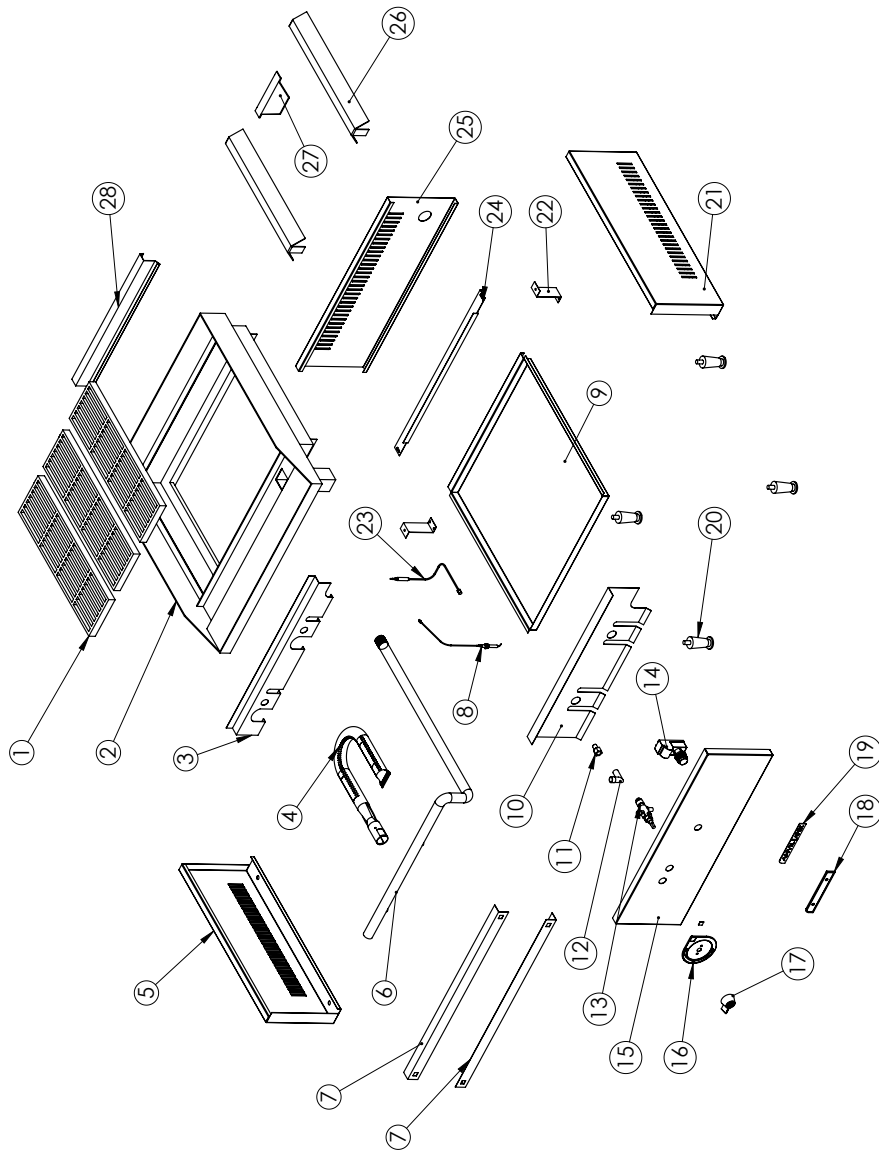

SAFETY

READ ALL INSTRUCTIONS BEFORE USE. FAILURE TO FOLLOW THESE PRECAUTIONS COULD RESULT IN INJURY TO YOURSELF AND OTHERS

1. When these units are to be positioned in close proximity to a wall, partitions, kitchen furniture, decorative finishes, etc. it is recommended that they be made of non-combustible material. If not, they shall be clad with a suitable non-combustible heat insulating material, and the closest attention be paid to fire prevention regulations.
2. Do not use an appliance that is damaged, leaking or which does not operate properly.
3. Ensure that the gas cylinder is connected or changed in well ventilated area, preferably outdoor, away from any source of ignition as open flames, and away from other people.
4. Keep gas cylinder away from heat and flames. Do not place on a stove or any other hot surface.
5. Ensure that the assembled unit is stable and does not rock.
6. Do not cover or change the primary air supply apertures in the burner as this will affect the performance of the product and may lead to unstable flames.
7. If there is a leak on your appliance (smell of gas), turn off the gas supply, first at the control valve on the cylinder and then on your appliance by turning the control knobs fully clockwise.
8. If you wish to check for leaks on your appliance, do it outside. Do not try to detect leaks using a flame. The correct way is to smear the joint with soapy water. If bubbles form, then there is a gas leak. Immediately turn off the gas supply first closing the control valve on the gas cylinder and then the appliance valves. Check that all the connections are properly fitted. Recheck with soapy water. If a gas leak persists, return the product to your dealer for inspection/repair.
9. Do not modify the appliance or use it for anything other than what it has been designed.
10. During use, part of the appliance will become hot, particularly the cooking areas and top. Avoid touching hot parts with your bare hands. The use of oven gloves is recommended.
12. Keep young children away from the appliance at all times.
13. This appliance consumes oxygen and needs ventilation for optimum performance and for the safety of those in close proximity.

EMERGENCY DRILL:

It is recommended that commercial kitchens have a suitable placed and sized fire extinguisher.

NOTE: Keep kitchen clean, particularly from fatty build up, especially in the vent ducting, as this is frequently the point of ignition.

IF YOU SHOULD SMELL GAS:

- * Turn off gas supply at cylinder.
- * DO NOT switch electrical equipment ON or OFF
- * Open all doors and windows to increase ventilation.
- * Extinguish open flames
- * Move cylinder outside if safe
- * Look for leaks with soapy water
- * No smoking

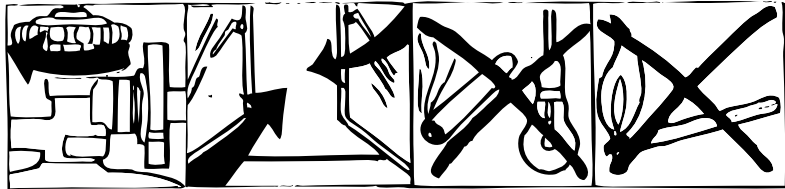
**IMPORTANT INFORMATION FOR THE USER**

This appliance may only be installed by a registered LP Gas installer. All

registered installers are issued with a card carrying their registration number. Ask to be shown the card before allowing the installation to commence and make a note of the Installer QCC number. Upon completion of the installation, the installer is required to explain the operational details of the appliance together with the safety instructions. You will be asked to sign acceptance of the installation and be provided with a completion certificate. You should only sign acceptance of the installation when the installation is completed to your satisfaction. Note that your invoice is required in the event that you wish to make a guarantee claim.

FLAT TOP GRILLER MODEL CODE: CBF0900

Part No.	Stock Code	Description
1		SPLASH GUARD PLATE ASSEMBLY
2		FIRE WALL
3	7-BURNER-CBF-1	BURNER
4		LEFT SIDE PANEL
5	7-MAN-GGR0400	MANIFOLD
6		CROSS BRACKET TOP AND BOTTOM
7	7-SP-GGR0400	SPARK PLUG WITH WIRE
8		DRIP TRAY
9		FRONT FIRE WALL
10	7-JET-GGR0400	JET
11	7-ELB-GGR0400	ELBOW
12	7-VAL-FTG0300	CONTROL VALVE
13	7-IS-GGR0400	IGNITION SWITCH
14		FRONT PANEL
15	4-BEZ-COA3004	GAS CONTROL BEZEL
16	3-KNOB-LEAVER	LEVER KNOB
17	4-DL-L-APEX	DOMED LABEL APEX
18	4-BEZ-BADGE	BADGE BEZEL
19	7-FOOT-FTA7016	ADJUSTABLE FOOT
20		RIGHT SIDE PANEL
21		BURNER SURPORT BRACKET
22		BURNER SURPORT BRACE
23	7-TC-GGR0400	PREMIER GAS RANGE THERMOCOUPLE
24		BACK PANEL

**EXPLODED DIAGRAM
FLAT TOP GRILLER
CBF0900**

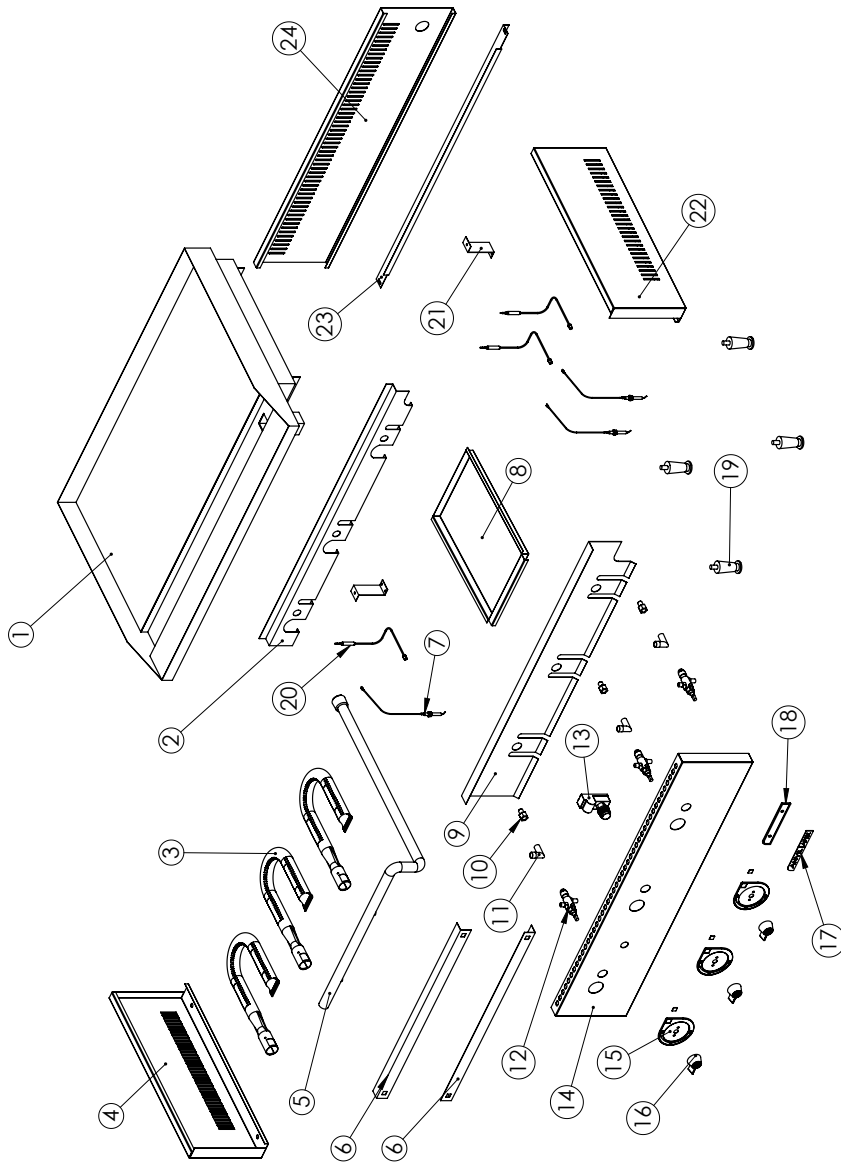

IMPORTANT INFORMATION FOR THE INSTALLER

This appliance may only be installed by LP gas installer registered with the LPGASA .The appliance must be installed with the requirements of SANS10087-1 and any fire department regulation and/or local bylaws applicable to the area. If in doubt check with the relevant authority before undertaking the installation. Upon completion of the installation you are required to fully explain and demonstrate to the user the operational details and safety practises applicable to the appliance and the installation.

FIRE AT CYLINDERS

(A) Don't panic - Flames from joints near a cylinder are not dangerous in themselves, as long as they do not heat up the cylinder.

(B) If possible, close the cylinder valve using a wet cloth to protect your hand.

(C) Spray cold water onto cylinders exposed to the fire in order to keep them cool. Use a hose pipe. Keep people away from the area.

DESCRIPTION OF MODELS

MODEL	DESCRIPTION	BURNERS	POWER (BTU)
CBF0300	300mm FLAT TOP GRILLER	1	28000
CBF0400	400mm FLAT TOP GRILLER	1	28000
CBF0600	600mm FLAT TOP GRILLER	2	56000
CBF0900	900mm FLAT TOP GRILLER	3	84000
CBF1200	1200mm FLAT TOP GRILLER	4	112000
CBF1500	1500mm FLAT TOP GRILLER	5	140000
CBL0300	300mm RADIANT CHARBROILER	1	28000
CBL0400	400mm RADIANT CHARBROILER	1	28000
CBL0600	600mm RADIANT CHARBROILER	2	56000
CBL0900	900mm RADIANT CHARBROILER	3	84000
CBL1200	1200mm RADIANT CHARBROILER	4	112000
CBL1500	1500mm RADIANT CHARBROILER	5	140000

**POSITIONING DIAGRAM
FLAT TOP GRILLER**

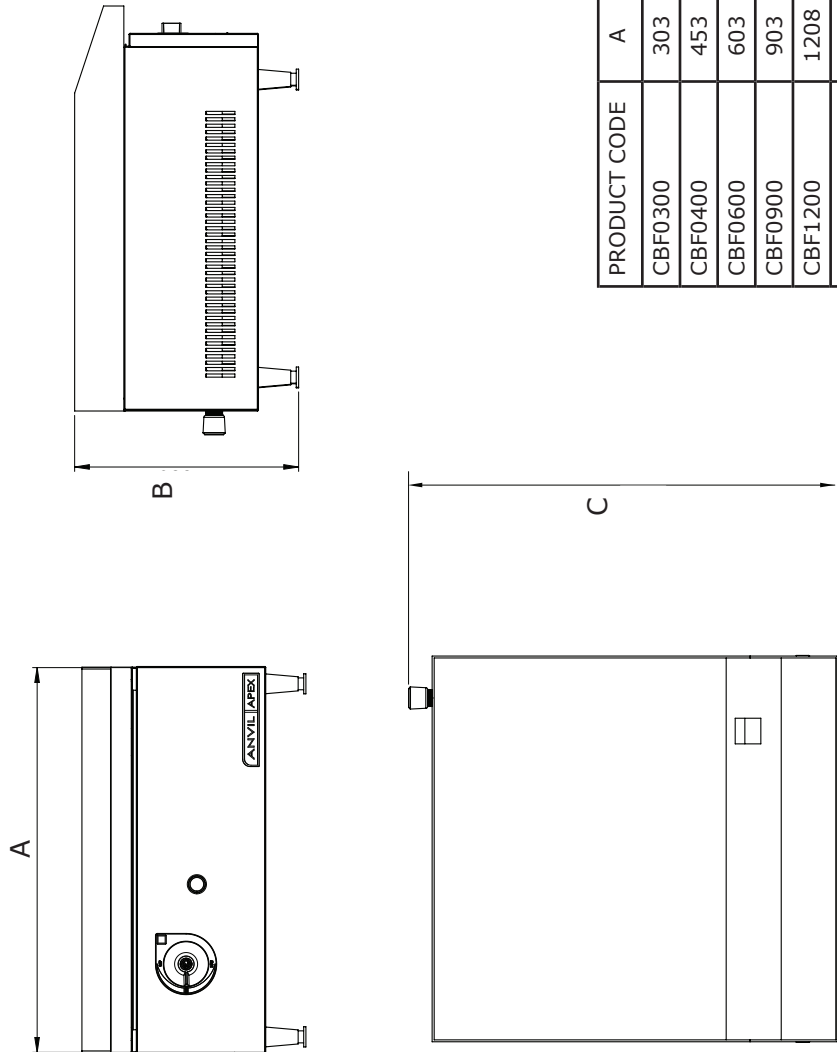

PRODUCT CODE	A	B	C
CBF0300	303	350	700
CBF0400	453	350	700
CBF0600	603	350	700
CBF0900	903	350	700
CBF1200	1208	350	700
CBF1500	1514	350	700

**FLAT TOP GRILLER
MODEL CODE: CBF0600**

Part No.	Stock Code	Description
1		SPLASH GUARD PLATE ASSEMBLY
2		FIRE WALL
3	7-BURNER-CBF-1	BURNER
4		LEFT SIDE PANEL
5	7-MAN-GGR0400	MANIFOLD
6		CROSS BRACKET TOP AND BOTTOM
7	7-SP-GGR0400	SPARK PLUG WITH WIRE
8		DRIP TRAY
9		FRONT FIRE WALL
10	7-JET-GGR0400	JET
11	7-ELB-GGR0400	ELBOW
12	7-VAL-FTG0300	CONTROL VALVE
13	7-IS-GGR0400	IGNITION SWITCH
14		FRONT PANEL
15	4-BEZ-COA3004	GAS CONTROL BEZEL
16	3-KNOB-LEAVER	LEVER KNOB
17	4-DL-L-APEX	DOMED LABEL APEX
18	4-BEZ-BADGE	BADGE BEZEL
19	7-FOOT-FTA7016	ADJUSTABLE FOOT
20		RIGHT SIDE PANEL
21		BURNER SURPORT BRACKET
22		BURNER SURPORT BRACE
23	7-TC-GGR0400	PREMIER GAS RANGE THERMOCOUPLE
24		BACK PANEL

**EXPLODED DIAGRAM
FLAT TOP GRILLER
CBF0600**

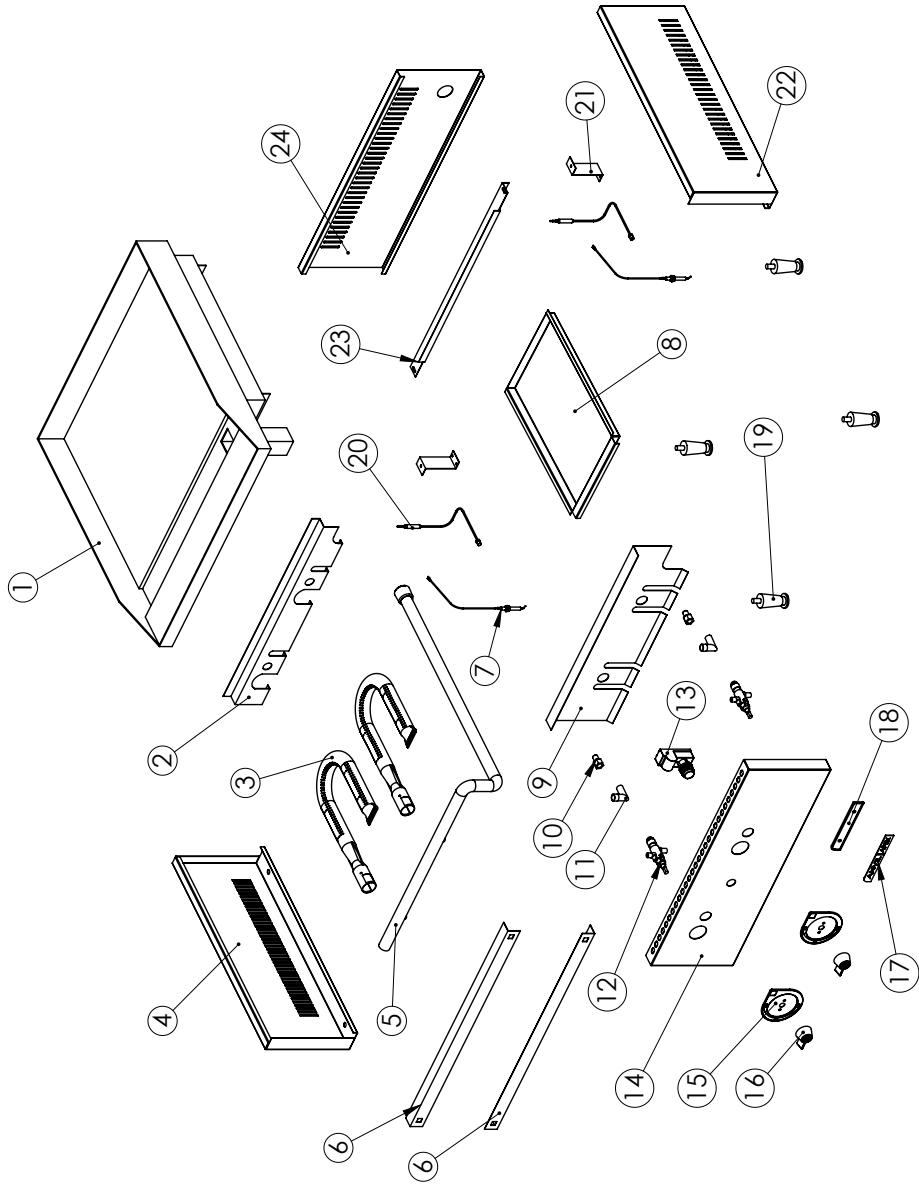

**POSITIONING DIAGRAM
GAS RADIANT CHARBROILER**

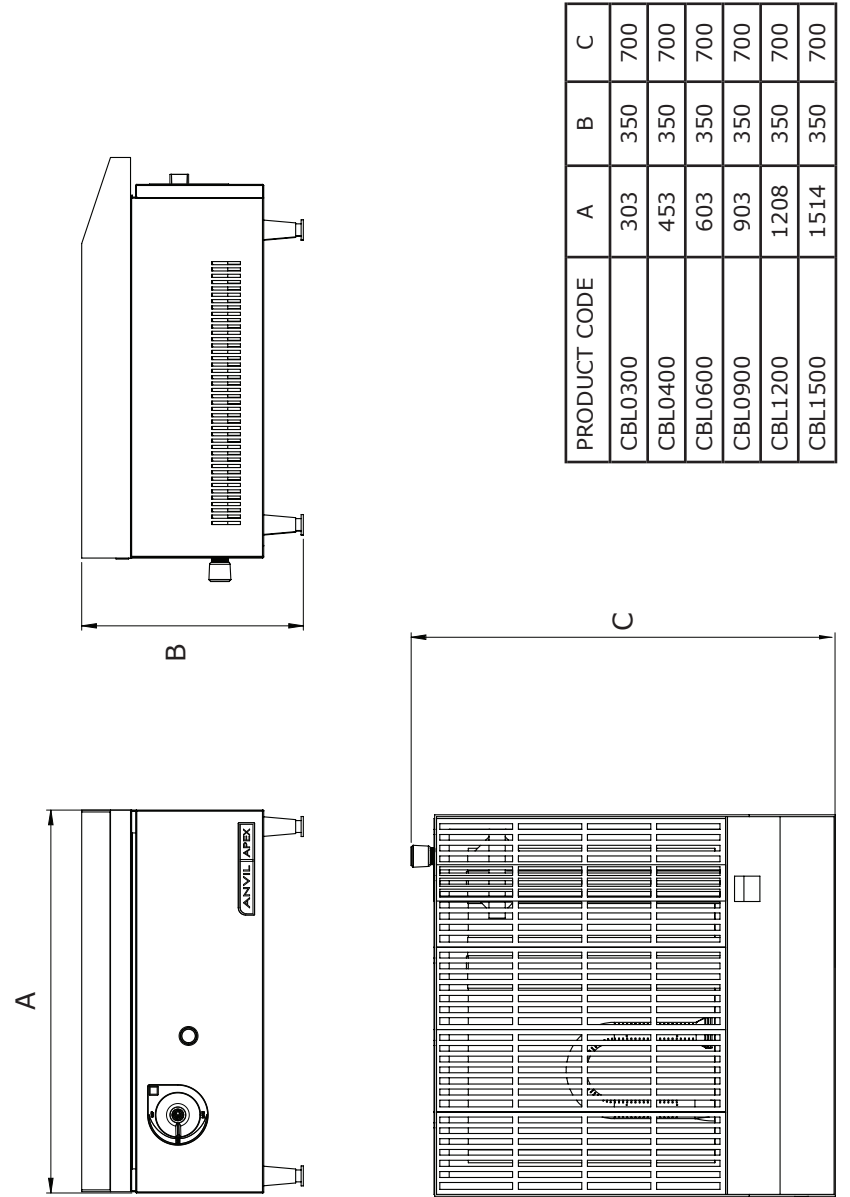

**EXPLODED DIAGRAM
FLAT TOP GRILLER
CBF0400**

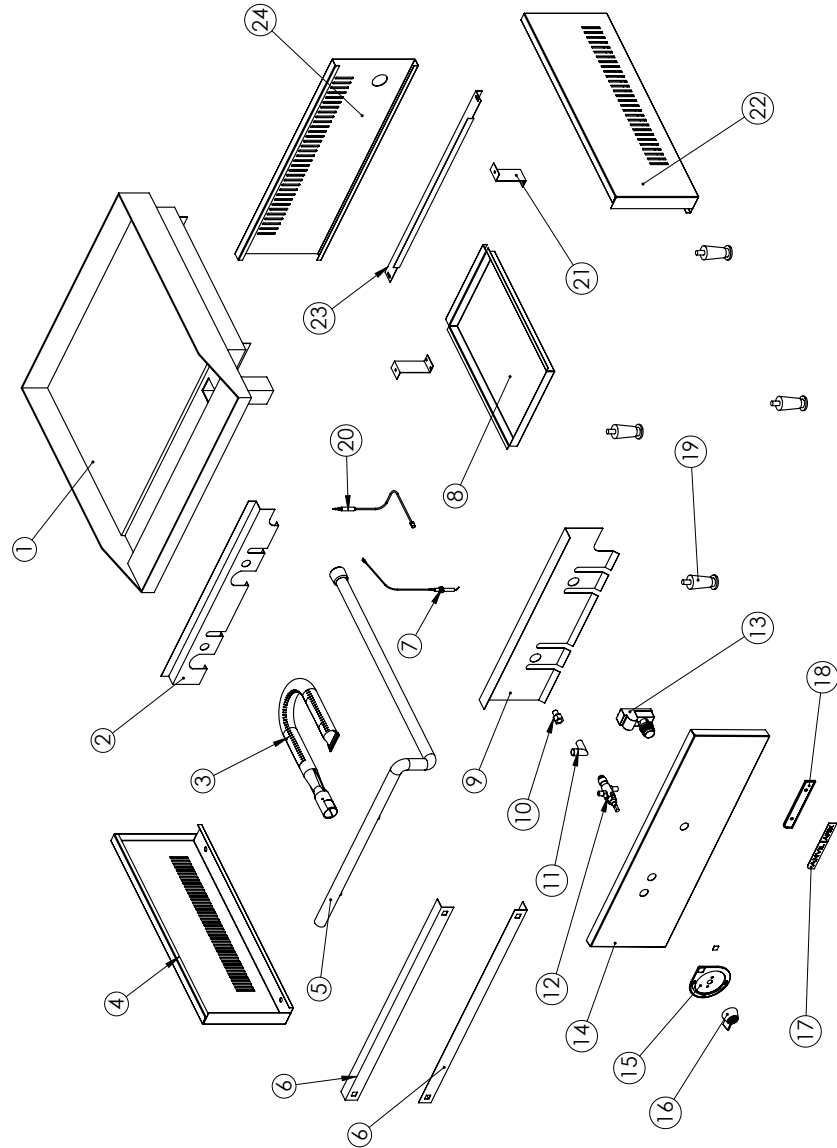

**FLAT TOP GRILLER
MODEL CODE: CBF0400**

Part No.	Stock Code	Description
1		SPLASH GUARD PLATE ASSEMBLY
2		FIRE WALL
3	7-BURNER-CBF-1	BURNER
4		LEFT SIDE PANEL
5	7-MAN-GGR0400	MANIFOLD
6		CROSS BRACKET TOP AND BOTTOM
7	7-SP-GGR0400	SPARK PLUG WITH WIRE
8		DRIP TRAY
9		FRONT FIRE WALL
10	7-JET-GGR0400	JET
11	7-ELB-GGR0400	ELBOW
12	7-VAL-FTG0300	CONTROL VALVE
13	7-IS-GGR0400	IGNITION SWITCH
14		FRONT PANEL
15	4-BEZ-COA3004	GAS CONTROL BEZEL
16	3-KNOB-LEAVER	LEVER KNOB
17	4-DL-L-APEX	DOMED LABEL APEX
18	4-BEZ-BADGE	BADGE BEZEL
19	7-FOOT-FTA7016	ADJUSTABLE FOOT
20		RIGHT SIDE PANEL
21		BURNER SURPORT BRACKET
22		BURNER SURPORT BRACE
23	7-TC-GGR0400	PREMIER GAS RANGE THERMOCOUPLE
24		BACK PANEL