

PLANETARY MIXER 20ℓ - NO HUB

MANUFACTURING
SINCE 1966



Model: PMF5020



FEATURES

- All mixers come standard with a dough hook, whisk and flat beater
- Stainless Steel safety guard
- Safety guard and bowl micro-switch cuts off the machine in the event of being opened while in use
- Mixers are coated with long lasting enamel which make them easy to clean and toxin free
- Hardened steel alloy gears with 3 speed transmission



ALL ANVIL EQUIPMENT COMES WITH A TWO YEAR WARRANTY ON COMPONENTS AND DEFECTIVE WORKMANSHIP.

www.anvilworld.com

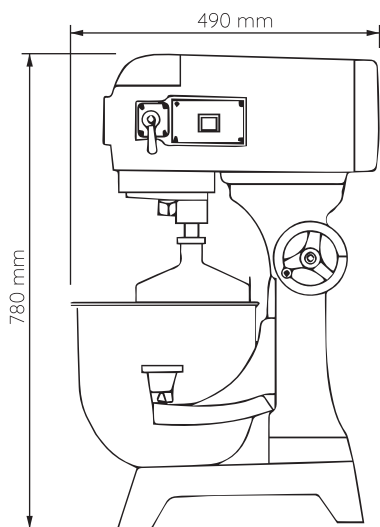
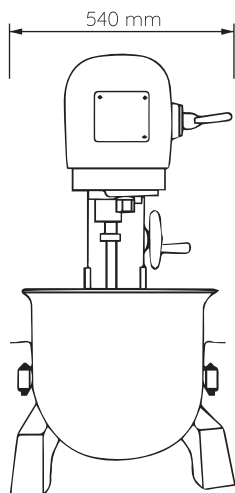
Model: PMF5020**SPECIFICATIONS**

POWER	1.1kW
VOLTAGE	230V - 50Hz - 2Phase
PACKAGING (W x D x H)	640 x 500 x 960 (mm)
UNIT (W x D x H)	540 x 490 x 780 (mm)
NET WEIGHT	66.5kg
GROSS WEIGHT	87kg
SHIPPING VOLUME	0.31m ³
PLANETARY SPEED	197 / 317 / 462rpm
CAPACITY	20ℓ

NOTE

- When viewing the appliance from the front in its usual operating position, the width (W) of the product is the total distance from left to right; the depth (D) of the product is the total distance from the front to the back; the height (H) is the total distance from the bottom of the product to the top. Pictures may vary from actual product.

DISCLAIMER

- Output performance figures quoted are dependent on various factors. Anvil reserves the right, without notice, to make changes and revisions to product specifications, materials and design, when we believe it will provide better performance, durability, and efficiency. Unit measurements may vary depending on point of reference.



ALL ANVIL EQUIPMENT COMES WITH A TWO YEAR WARRANTY ON COMPONENTS AND DEFECTIVE WORKMANSHIP.

www.anvilworld.com