

PIE WARMER 640mm

MANUFACTURING
SINCE 1966



Model: PWK0004



FEATURES

- This unit is ideal for use in small supermarkets or fast-food outlets
- Thermostatically controlled temperature
- Rear sliding doors
- Easily removable crumb tray
- Full Stainless Steel double wall construction, keeps outside wall cool
- Operating temperature: 50°C - 80°C



ALL ANVIL EQUIPMENT COMES WITH A TWO YEAR WARRANTY ON COMPONENTS AND DEFECTIVE WORKMANSHIP.

www.anvilworld.com

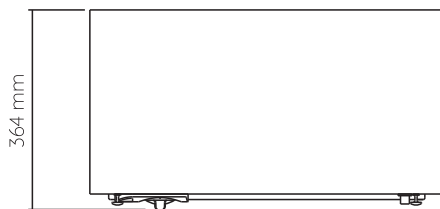
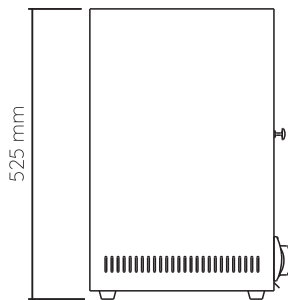
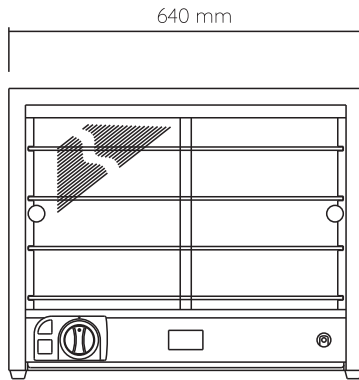
Model: PWK0004**SPECIFICATIONS**

POWER	1kW
VOLTAGE	230V - 50Hz
PACKAGING (W x D x H)	690 x 400 x 590 (mm)
UNIT (W x D x H)	640 x 364 x 525 (mm)
NET WEIGHT	21kg
GROSS WEIGHT	27kg
SHIPPING VOLUME	0.16m ³
CAPACITY	Approx 30 standard size pies

AVAILABLE IN

 120V/60Hz**NOTE**

- When viewing the appliance from the front in its usual operating position, the width (W) of the product is the total distance from left to right; the depth (D) of the product is the total distance from the front to the back; the height (H) is the total distance from the bottom of the product to the top. Pictures may vary from actual product.

DISCLAIMER

- Output performance figures quoted are dependent on various factors. Anvil reserves the right, without notice, to make changes and revisions to product specifications, materials and design, when we believe it will provide better performance, durability, and efficiency.



ALL ANVIL EQUIPMENT COMES WITH A TWO YEAR WARRANTY ON COMPONENTS AND DEFECTIVE WORKMANSHIP.

www.anvilworld.com