

PIE WARMER 865mm

MANUFACTURING
SINCE 1966



Model: PWK0005



FEATURES

- This unit is ideal for use in small supermarkets or fast-food outlets
- Thermostatically controlled temperature
- Rear sliding doors
- Easily removable crumb tray
- Full Stainless Steel double wall construction, keeps outside wall cool
- Operating temperature:
50°C - 80°C



ALL ANVIL EQUIPMENT COMES WITH A TWO YEAR WARRANTY ON COMPONENTS AND DEFECTIVE WORKMANSHIP.

www.anvilworld.com

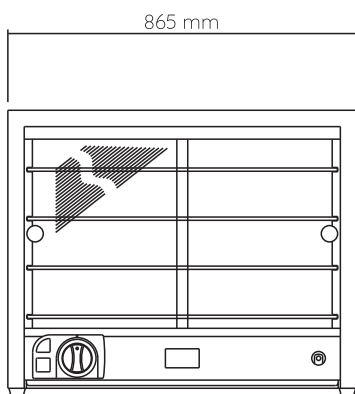
Model: PWK0005

SPECIFICATIONS

POWER	1kW
VOLTAGE	230V - 50Hz
PACKAGING (W x D x H)	920 x 400 x 670 (mm)
UNIT (W x D x H)	865 x 364 x 525 (mm)
NET WEIGHT	31kg
GROSS WEIGHT	33kg
SHIPPING VOLUME	0.25m ³
CAPACITY	Approx 50 standard size pies

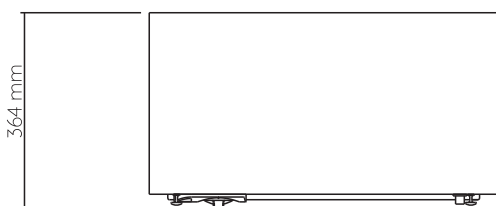
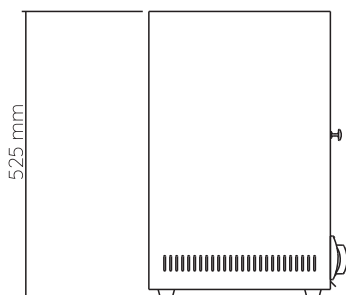
AVAILABLE IN

 120V/60Hz

NOTE

- When viewing the appliance from the front in its usual operating position, the width (W) of the product is the total distance from left to right; the depth (D) of the product is the total distance from the front to the back; the height (H) is the total distance from the bottom of the product to the top. Pictures may vary from actual product.

DISCLAIMER

- Output performance figures quoted are dependent on various factors. Anvil reserves the right, without notice, to make changes and revisions to product specifications, materials and design, when we believe it will provide better performance, durability, and efficiency. Unit measurements may vary depending on point of reference.



ALL ANVIL EQUIPMENT COMES WITH A TWO YEAR WARRANTY ON COMPONENTS AND DEFECTIVE WORKMANSHIP.

www.anvilworld.com