

SALAMANDER INCOLOY

MANUFACTURING
SINCE 1966



Model: SAA0003



FEATURES

- Perfect for restaurants, pubs, coffee shops, cafes, etc
 - Comes standard with 1 crumb tray (Removable cover allows for front and rear access)
 - These salamanders are ideal for: toasting approx 200 - 400 slices an hour, defrosting of ready-made dishes, reheating pizzas, croissants, sausage rolls, fried eggs, etc
 - Gratinating onion soups, cheese sandwiches etc
 - Use as a plate warmer or pass through hatch
- NOTE:**
- Comes with 2 removable shelf lifting handles



ALL ANVIL EQUIPMENT COMES WITH A TWO YEAR WARRANTY ON COMPONENTS AND DEFECTIVE WORKMANSHIP.

www.anvilworld.com

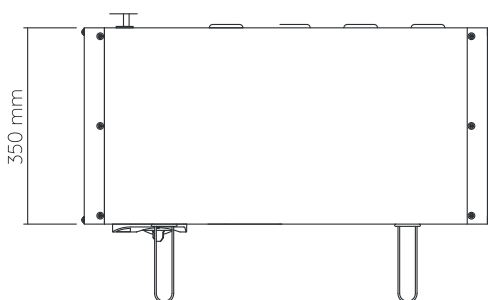
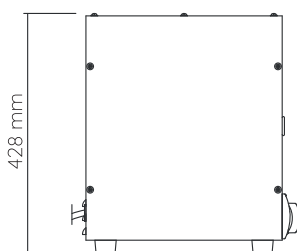
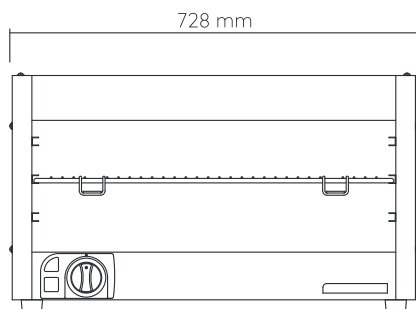
Model: SAA0003**SPECIFICATIONS**

POWER	2.8kW
VOLTAGE	230V - 50Hz - 2Phase
PACKAGING (W x D x H)	780 x 440 x 440 (mm)
UNIT (W x D x H)	728 x 350 x 428 (mm)
SHELF DIMENSIONS	330 x 640 (mm)
RUNNER SPACE	65mm
NET WEIGHT	15.6kg
GROSS WEIGHT	16.4kg
SHIPPING VOLUME	0.15m ³

NOTE

- When viewing the appliance from the front in its usual operating position, the width (W) of the product is the total distance from left to right; the depth (D) of the product is the total distance from the front to the back; the height (H) is the total distance from the bottom of the product to the top. Pictures may vary from actual product.

DISCLAIMER

- Output performance figures quoted are dependent on various factors. Anvil reserves the right, without notice, to make changes and revisions to product specifications, materials and design, when we believe it will provide better performance, durability, and efficiency. Unit measurements may vary depending on point of reference.



ALL ANVIL EQUIPMENT COMES WITH A TWO YEAR WARRANTY ON COMPONENTS AND DEFECTIVE WORKMANSHIP.

www.anvilworld.com