

## WALL MOUNT SHELF 600mm

MANUFACTURING  
SINCE 1966



**Model: SSW0600**

### FEATURES

- All stainless steel construction
- A depth of 300mm
- Adjustable height
- 295mm max distance between shelves

- NOTE:**
- Shelves come flat packed for convenient transportation



ALL ANVIL EQUIPMENT COMES WITH A TWO YEAR WARRANTY ON COMPONENTS AND DEFECTIVE WORKMANSHIP.

[www.anvilworld.com](http://www.anvilworld.com)

**Model: SSW0600**
**SPECIFICATIONS**

PACKAGING (W x D x H)	630 x 320 x 100 (mm)
UNIT (W x D)	578 x 300 (mm)
NET WEIGHT	3kg
GROSS WEIGHT	3.2kg
SHIPPING VOLUME	0.02m <sup>3</sup>

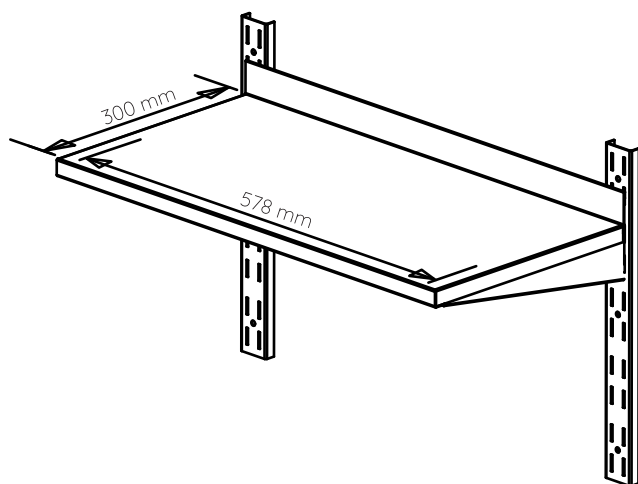
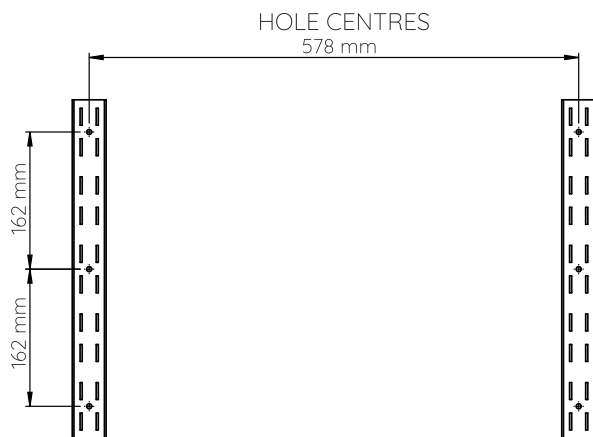
**NOTE**

- When viewing the appliance from the front in its usual operating position, the width (W) of the product is the total distance from left to right; the depth (D) of the product is the total distance from the front to the back; the height (H) is the total distance from the bottom of the product to the top. Pictures may vary from actual product.

**DISCLAIMER**

- Output performance figures quoted are dependent on various factors. Anvil reserves the right, without notice, to make changes and revisions to product specifications, materials and design, when we believe it will provide better performance, durability, and efficiency. Unit measurements may vary depending on point of reference.



**ALL ANVIL EQUIPMENT COMES WITH A TWO YEAR WARRANTY ON COMPONENTS AND DEFECTIVE WORKMANSHIP.**

[www.anvilworld.com](http://www.anvilworld.com)