

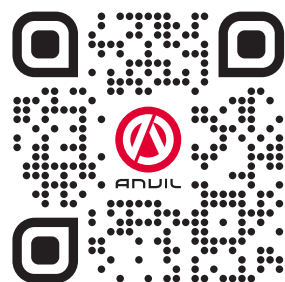

**ANVIL**

# Installation, Operation and Care Manual



SCAN ME  
TO GO TO  
WARRANTY  
REGISTRATION

MANUFACTURING  
SINCE 1966

4-INS-STA0001

THE CHEFS COMPANION



THE CHEFS COMPANION



THANK YOU FOR PURCHASING  
AN ANVIL PRODUCT!



**REGISTER ONLINE TODAY**

Register your warranty on-line at [www.anvilworld.com](http://www.anvilworld.com) today and learn how to get the best out of your Anvil product, tips to care for your Anvil product for long lasting performance, exciting recipes and more.

**NO WEB ACCESS?**

If you do not have access to the Web, register by completing this form and faxing it to the Anvil head office in South Africa. Fax: +27 11 474 1630

**ONLY COMPLETE IF YOU DO NOT HAVE WEB ACCESS**

Company \_\_\_\_\_

Name \_\_\_\_\_

Surname \_\_\_\_\_

Telephone \_\_\_\_\_

Cellphone \_\_\_\_\_

Email Address \_\_\_\_\_

Country \_\_\_\_\_

Postal address \_\_\_\_\_

\_\_\_\_\_

\_\_\_\_\_

Anvil products purchased \_\_\_\_\_

Code (see box label) \_\_\_\_\_

Serial number (see back of machine) \_\_\_\_\_

**INTENDED USE**

- Full-Service restaurant
- Coffee Shop / Deli
- Fast Food Outlet
- Hotel
- Bed & Breakfast
- School Cafeteria

- Institutional Cafeteria
- Corporate Catering
- Private Use
- Franchisor
- Convenience Store
- Other

 ALL ANVIL EQUIPMENT COMES WITH A TWO YEAR WARRANTY ON COMPONENTS AND DEFECTIVE WORKMANSHIP.

[www.anvilworld.com](http://www.anvilworld.com)

## LIMITED WARRANTY

All equipment which is sold under ANVIL trademark and used for commercial purposes is warranted against defects in materials and workmanship. The warranty runs for two years from the date of original installation and is for the benefit of the original purchaser only. All other Warranties ,expressed or implied , statutory or otherwise, including without limitations any implied Warranty of Merchantability or fitness for purpose are excluded .The Seller shall in no event be liable for direct,indirect or consequential damages in connection with ANVIL commercial products.

The Sellers obligation under this Warranty is limited to the repair of defects without charge. Defective units must be taken or shipped,transportation charges prepaid,to ANVIL.

This Warranty is not effective if damage occurs because of accident,carelessness,improper installation,lack of proper set-up,supervision when required or if the equipment is installed or operated in any manner contrary to the installation and operating instructions. In these cases,repairs will be made at a reasonable cost. Work performed by unauthorized personnel or unauthorized service agencies using non Anvil spares voids this Warranty.



**NB:**

### REGISTER ON-LINE TODAY

Register your warranty on-line now at [www.anvilworld.com](http://www.anvilworld.com)

### NO WEB ACCESS

If you do not have access to the Web. Kindly register by completing the warranty registration form and fax it to the ANVIL office in the country of purchase.

**Failure to do so will invalidate your warranty.**

## STOVE PLATE

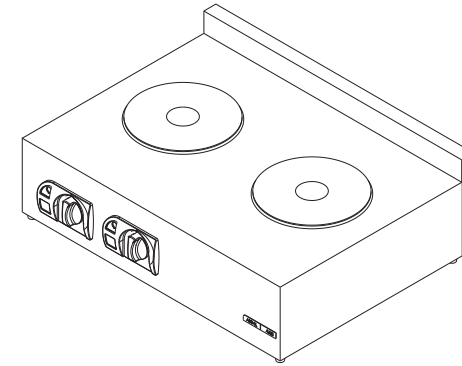

**INSTALLATION OPERATION AND CARE OF  
SINGLE /DOUBLE STOVE PLATE  
MODELS: STA0001 R03 /STA0002 R03**

## UNPACKING

Unpack the product and check for any damage incurred during transit. This should be reported to the responsible carrier, railway or postal authority, and a request for a damage report should be made.



THESE INSTRUCTIONS MUST BE FOLLOWED FOR US TO GUARANTEE OUR FULL SUPPORT OF YOUR CLAIM FOR PROTECTING AGAINST LOSS FROM CONCEALED DAMAGE. THE FORM FOR FILING SUCH A CLAIM WILL BE PROVIDED BY THE CARRIER.

## GENERAL INSTALLATION AND OPERATION INSTRUCTIONS

1. The top working surface has a heat resistant coating. Before using the sealed hotplate for the first time, it should be heated for  $\pm 5$  minutes at setting no. 2. This will enable the protective coating to harden and burn off.
2. Use only good quality pans on the sealed hotplates. They should have a stable bottom to ensure the greatest possible contact with the sealed hotplate during operation. This will result in maximum use of energy.
3. Use pans of the correct diameter only. They should cover the sealed hotplate like an umbrella to allow any spillage to flow off easily.
4. If the pan is too small, energy is wasted and spillage can flow onto the sealed hotplate.
5. Anvil stoves are equipped with one pilot light which will remain illuminated when the unit is switched on.



## WARNING

### **Burn Hazard.**

Do not touch hot food, liquid or heating surfaces while equipment is heating or operating

Hot surfaces and food can burn skin. Allow the hot surfaces to cool before handling

### **CLEANING AND MAINTENANCE INSTRUCTIONS**

1. Always ensure that the unit is disconnected from the main power supply before cleaning.
2. The unit should not be cleaned with a water jet or immersed in water. Use only a damp cloth or sponge dipped in soapy water.
3. Always clean equipment thoroughly before first use. However, do not use chlorine or chloride – based products to clean the unit. These may lead to corrosion and pitting and will result in voiding the warranty on the unit.
4. Wipe off the unit with a dry cloth and wait at least half an hour before re – connecting to the main power outlet.



THIS APPLIANCE SHOULD NOT BE CLEANED WITH A WATER JET OR IMMERSSED IN WATER. USE ONLY A DAMP CLOTH OR SPONGE DIPPED IN SOAPY WATER. DO NOT USE STEEL-WOOL WHICH WILL MARK THE BRIGHT STAINLESS STEEL FINISH



## WARNING

### Electric Shock Hazard.

Keep water and other liquids from entering the inside of the equipment. Liquid inside the equipment could cause an electrical shock

Do not spray water or cleaning products. Liquid could contact the electrical components and cause a short circuit or an electrical shock. Do not use equipment if power cord is damaged or has been modified

### SAFETY

#### READ ALL INSTRUCTIONS BEFORE USE. FAILURE TO FOLLOW THESE PRECAUTIONS COULD RESULT IN INJURY TO YOURSELF AND OTHERS

1. When this appliance is to be positioned in close proximity to a wall, partitions, kitchen furniture, decorative finishes, etc. it is recommended that they be made of non-combustible material. If not, they shall be clad with a suitable non-combustible heat insulating material, and the closest attention be paid to fire prevention regulations.
2. Use the appliances on an individual 15A mains outlet only.  
**DO NOT OVERLOAD THE CIRCUIT.**
3. Ensure that the equipment and the power supply cord does not come into contact with hot surfaces.
4. Supervision is necessary when the appliance is used in close proximity to children.
5. If the supply cord is damaged, it must be replaced with a new cord assembly available from the suppliers agent.
6. Use only earthed outlets matching the serial plate voltage.
7. Have equipment installed by a qualified personnel in accordance with local codes and ordinances.
8. Use equipment in a flat level position.
9. Do not operate unattended
10. The equipment may be hot, even though the pilot light is not on.
11. Do not operate if equipment has been damaged or is malfunctioning in any way.
12. These appliances are designed to run only on alternating current (A.C.) **DO NOT CONNECT TO DIRECT CURRENT (D.C)**

## MODEL: DOUBLE PLATE STOVE MODEL CODE: STA0002 R03

Part No.	Description
1	220mm SOLID HOT PLATE
2	180mm SOLID HOT PLATE
3	BODY ASSEMBLY
4	7 STAGE SELECTOR SWITCH
5	CONTROL PANEL FACIA
6	PILOT LIGHT
7	FACIA PANEL INSERT
8	CONTROL KNOB
9	ANVIL AXIS LOGO
10	BOTTOM COVER
11	SMALL RUBBER FOOT
12	SMALL PLATE CLAMP
13	LARGE PLATE CLAMP
14	LARGE HEAT SHIELD
15	SMALL HEAT SHIELD
16	POLYAMIDE TERMINAL BLOCK
17	STRAIN RELIEF
18	POWER CORD

**EXPLODED DIAGRAM  
DOUBLE STOVE  
MODEL: STA0002 R02**

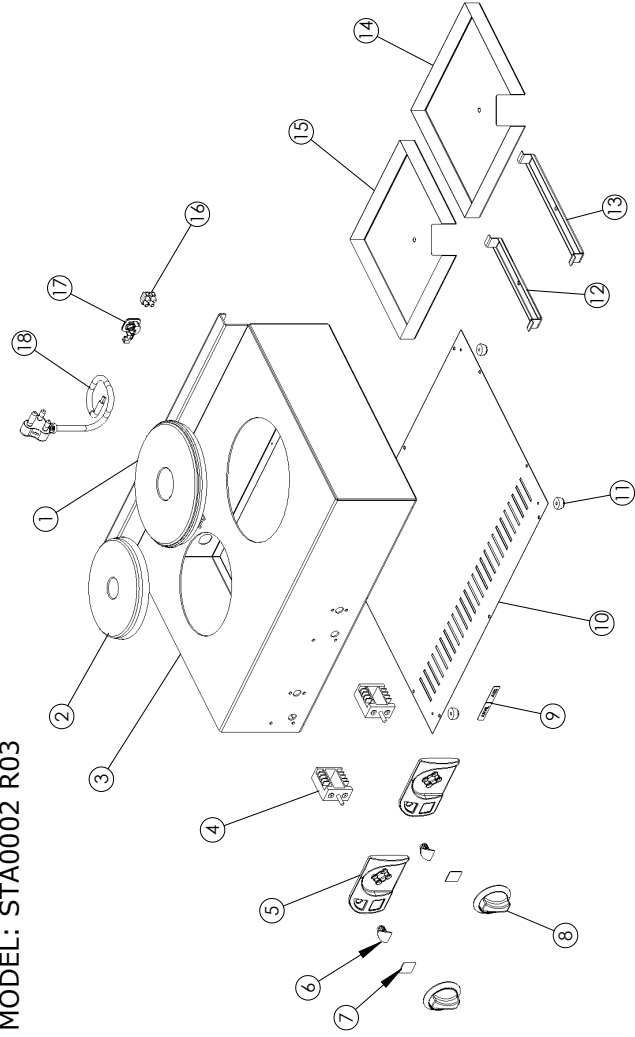

**EXPLODED DIAGRAM  
DOUBLE PLATE STOVE  
MODEL: STA0002 R03**

**POSITIONING DIAGRAM  
SINGLE STOVE  
MODEL: STA0001 R02**

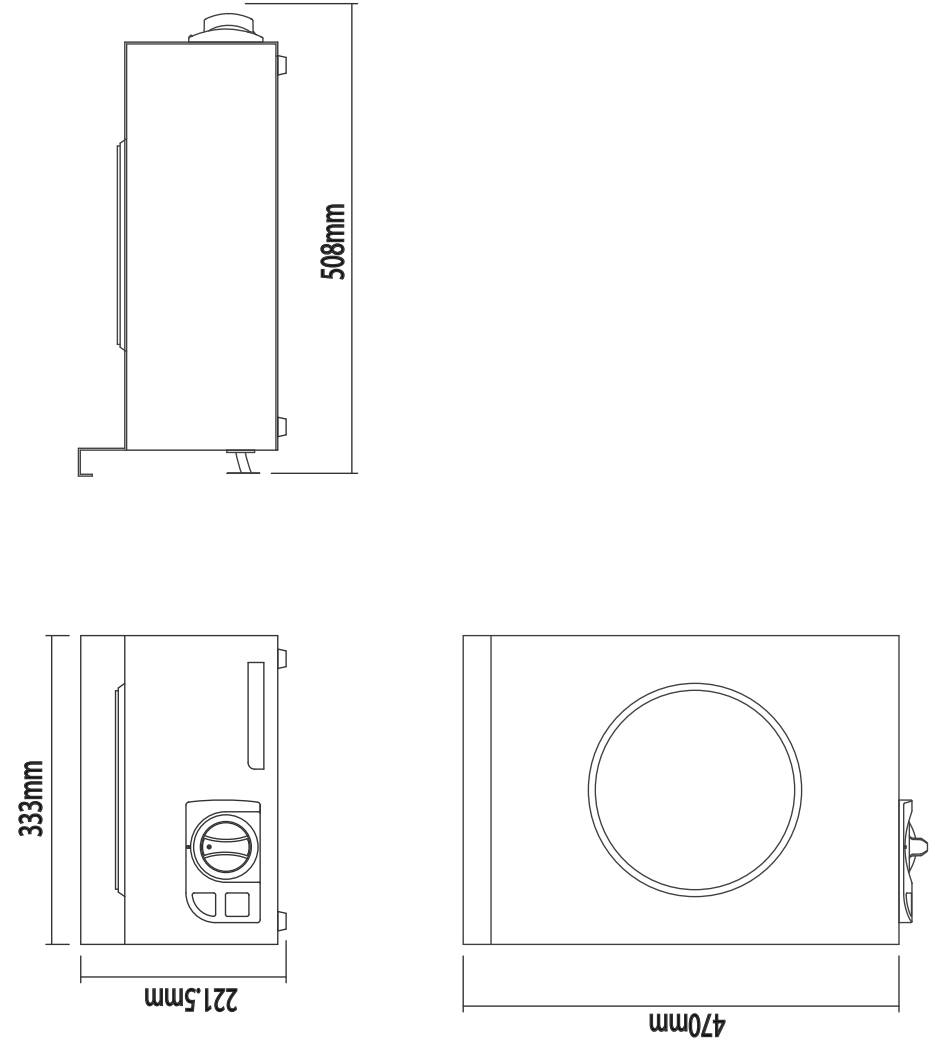

**POSITIONING DIAGRAM  
DOUBLE STOVE PLATE  
MODEL: STA0002 R02**

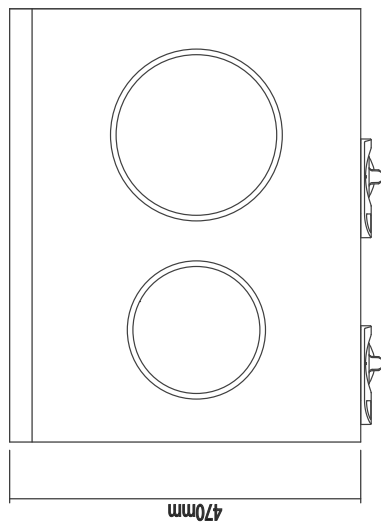
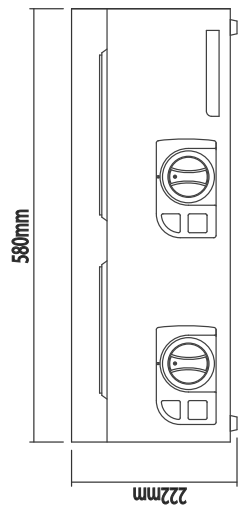
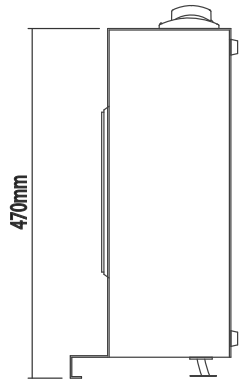

**MODEL:SINGLE PLATE STOVE  
MODEL CODE : STA0001 R03**

Part No.	Description
1	220mm SOLID HOT PLATE
2	BODY ASSEMBLY
3	7 STAGE SELECTOR SWITCH
4	CONTROL PANEL FACIA
5	PILOT LIGHT
6	FACIA PANEL INSERT
7	CONTROL KNOB
8	ANVIL AXIS LOGO
9	SMALL RUBBER FOOT
10	BOTTOM COVER
11	LARGE HEAT SHIELD
12	LARGE PLATE CLAMP
13	POLYAMIDE TERMINAL BLOCK
14	STRAIN RELIEF
15	POWER CORD



**EXPLODED DIAGRAM  
SINGLE STOVE  
MODEL: STA0001 R03**

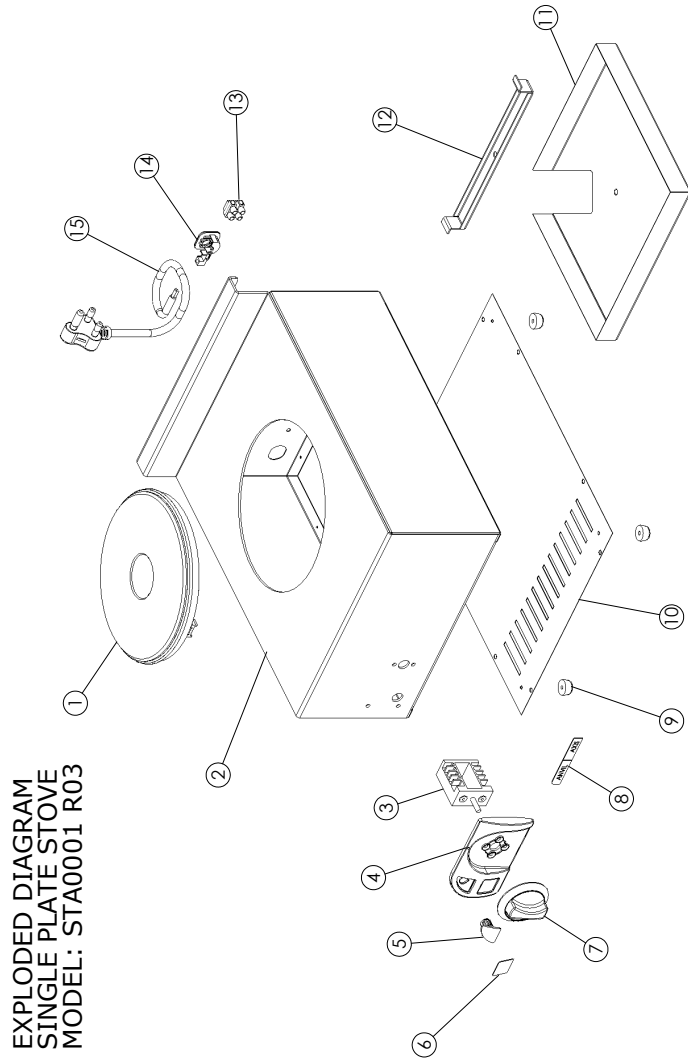

EXPLODED DIAGRAM  
SINGLE PLATE STOVE  
MODEL: STA0001 R03

**ELECTRICAL CONNECTION INFORMATION**

MODEL	DESCRIPTION	VOLTS (V/Hz)	POWER (W)
STA0001	SINGLE PLATE STOVE	230/50	2000
STA0002	DOUBLE PLATE STOVE	230/50	3200



IT IS ESSENTIAL TO MAKE SURE THAT THE INCOMING VOLTAGE IS THE SAME AS THE RATED VOLTAGE OF THE OF THE UNIT AS FOUND ON THE SERIAL PLATE. THE SERIAL PLATE IS LOCATED AT THE REAR OF THE UNIT ADJACENT TO THE INCOMING CABLE ENTRY.

**WIRING DIAGRAM  
SINGLE STOVE PLATE  
MODEL CODE: STA0001 R02**

LEGEND	DESCRIPTION	PART NUMBER
S1	SEVEN POSITION STAGE SWITCH	1-SW-7P
E1	STOVE PLATE ELEMENT - 2000W/230V	5-2000W-SP
H1	CONTROL PILOT LIGHT	1-PL-BMA0001

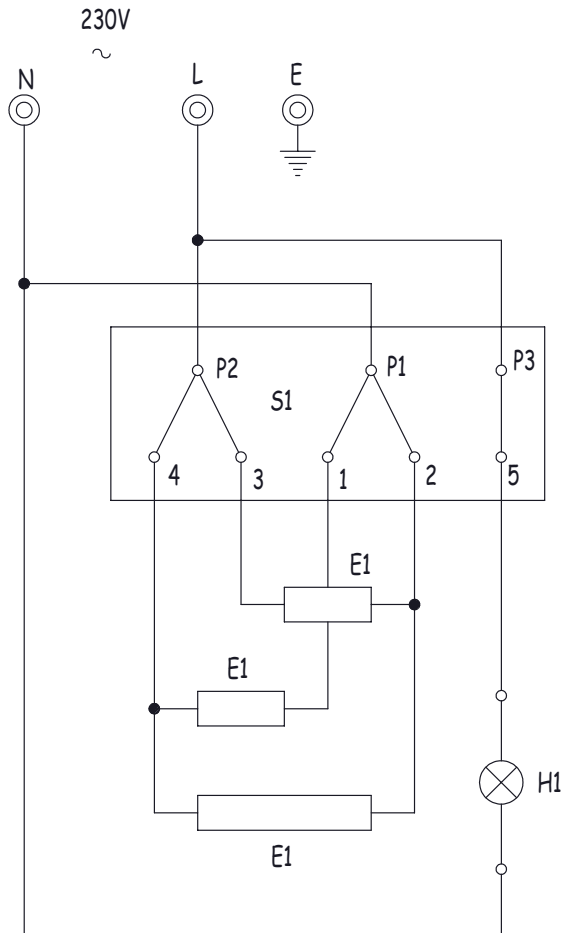

**WIRING DIAGRAM  
DOUBLE STOVE PLATE  
MODEL CODE: STA0002 R02**

LEGEND	DESCRIPTION	PART NUMBER
S1/S2	SEVEN POSITION STAGE SWITCH	1-SW-7P
E1	ELEMENT - 2000W/230V	5-2000W-SP
E2	ELEMENT - 1200W/230V	5-1200W-SP
H1/H2	CONTROL PILOT LIGHT	1-PL-BMA0001

