

TILTING PAN

MANUFACTURING
SINCE 1966



Model: TPA0080



FEATURES

- Ideal for use in restaurants, canteens, institutions, etc.
- Smooth and robust tilting function
- Ideal for stews and many forms of bulk food preparation
- Easy to clean Stainless Steel pan
- Total power output of 12kW
- Rapidly heats up to operating temperature
- Water inlet control on front panel
- Automatic safety cut-off in the event of overheating
- Micro switch cuts out elements when pan is tilted



ALL ANVIL EQUIPMENT COMES WITH A TWO YEAR WARRANTY ON COMPONENTS AND DEFECTIVE WORKMANSHIP.

www.anvilworld.com

Model: TPA0080**SPECIFICATIONS**

POWER	12kW
VOLTAGE	380V - 50Hz - 3Phase
PACKAGING (W x D x H)	900 x 1140 x 1160 (mm)
UNIT (W x D x H)	800 x 900 x 960 (mm)
NET WEIGHT	220kg
GROSS WEIGHT	235kg
SHIPPING VOLUME	1.19m ³
CAPACITY	80ℓ

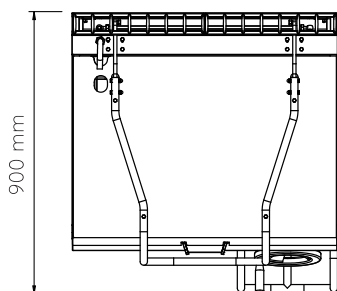
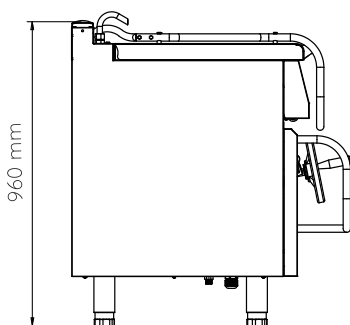
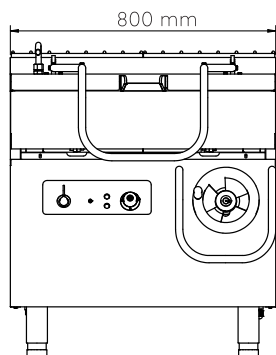
**NOTE**

- When viewing the appliance from the front in its usual operating position, the width (W) of the product is the total distance from left to right; the depth (D) of the product is the total distance from the front to the back; the height (H) is the total distance from the bottom of the product to the top. Pictures may vary from actual product.

DISCLAIMER

- Output performance figures quoted are dependent on various factors. Anvil reserves the right, without notice, to make changes and revisions to product specifications, materials and design, when we believe it will provide better performance, durability, and efficiency. Unit measurements may vary depending on point of reference.



ALL ANVIL EQUIPMENT COMES WITH A TWO YEAR WARRANTY ON COMPONENTS AND DEFECTIVE WORKMANSHIP.

www.anvilworld.com