

LIMITED WARRANTY

All equipment which is sold under ANVIL trademark and used for commercial purposes is warranted against defects in materials and workmanship. The warranty runs for two years from the date of original installation and is for the benefit of the original purchaser only. All other Warranties ,expressed or implied , statutory or otherwise, including without limitations any implied Warranty of Merchantability or fitness for purpose are excluded .The Seller shall in no event be liable for direct,indirect or consequential damages in connection with ANVIL commercial products.

The Sellers obligation under this Warranty is limited to the repair of defects without charge. Defective units must be taken or shipped,transportation charges prepaid,to ANVIL.

This Warranty is not effective if damage occurs because of accident,carelessness,improper installation,lack of proper set-up,supervision when required or if the equipment is installed or operated in any manner contrary to the installation and operating instructions. In these cases,repairs will be made at a reasonable cost. Work performed by unauthorized personnel or unauthorized service agencies using non Anvil spares voids this Warranty.



NB:

REGISTER ON-LINE TODAY

Register your warranty on-line now at www.anvilworld.com

NO WEB ACCESS

If you do not have access to the web. Kindly register by completing the warranty registration form and fax it to the anvil office in the country of purchase.

Failure to do so will invalidate your warranty.

FLAT TOP GRILLER ELECTRIC

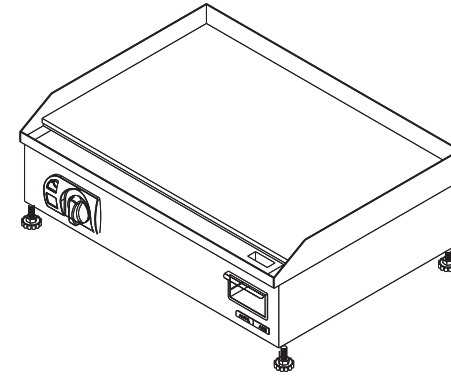

INSTALLATION OPERATION AND CARE OF FLAT TOP GRILLER ELECTRIC

**MODELS: FTA0400 R03/FTA0400-120 R01/FTA4400 R04
FTA4400-120 R01/FTA2600 R03
FTA0600 R03/FTA1600 R02 / FTA0900 R01 /
FTA4600 R02**

UNPACKING

Unpack the product and check for any damage incurred during transit. This should be reported to the responsible carrier, railway or postal authority, and a request for a damage report should be made.



THESE INSTRUCTIONS MUST BE FOLLOWED FOR US TO GUARANTEE OUR FULL SUPPORT OF YOUR CLAIM FOR PROTECTING AGAINST LOSS FROM CONCEALED DAMAGE. THE FORM FOR FILING SUCH A CLAIM WILL BE PROVIDED BY THE CARRIER.

GENERAL INSTALLATION AND OPERATION INSTRUCTIONS

1. Before using the griller, turn the knob to maximum temperature. Allow the griller to burn in for +/-30 minutes. You will notice smoke appearing due to the protective coatings burning in. This is normal.
2. After the burning in period has lapsed, turn the temperature control knob down to the desired operating temperature. Grease plates generously with butter or oil.
3. Never allow excess fat or oil to build up as this will result in the building up carbon on the plates. This can be removed with a scraper or grill brick.
4. The griller is provided with adjustable feet to enable the slope of the griller plate to be set towards the fat drain tray.

MODEL: 600mm FLAT TOP ELECTRIC GRILLER

MODEL CODE : FTA4600 R02

Part No.	Description
1	BODY ASSEMBLY
2	GRILLER THERMOSTAT
3	CONTROL PANEL FACIA
4	PILOT LIGHT
5	FACIA PANEL INSERT
6	CONTROL KNOB
7	GRILLER FAT TRAY
8	ANVIL AXIS LOGO
9	ELEMENT CLAMP
10	PROBE CLAMP
11	BOTTOM COVER
12	ELEMENT COVER
13	INSULATION PAD
14	GRILLER ELEMENT
15	FAT TRAY SHIELD
16	ADJUSTABLE FEET
17	3 PHASE CONNECTOR BLOCK
18	GRILLER TOP ASSEMBLY

**EXPLODED DIAGRAM
FLAT TOP GRILLER 6kW 2 PHASE
FTA4600 R02**

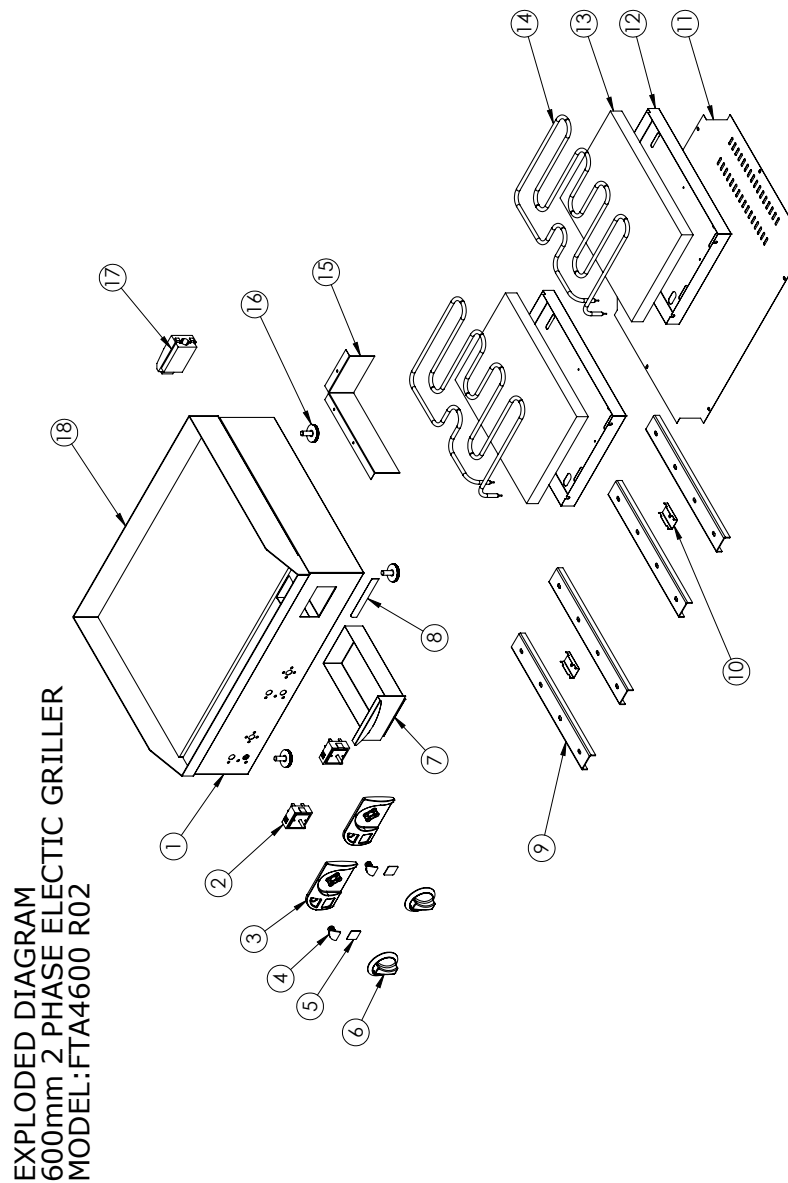

SPECIFIC INSTALLATION AND OPERATION INSTRUCTIONS

FTA 1600 – Egg and Bacon Griller

The griddle plate surface is divided into two halves, a flat half that can be thermostatically controlled to 300°C (570°F) and the other half, which is a tank, constructed onto the griddle surface. The temperature of the oil in the tank can be independently controlled via a thermostat to between 60 - 190°C (140°F - 374°F).

1. The unit is equipped with two pilot lights for either half, which will go out when the desired temperature is reached.
2. The oil tank is suitable for frying eggs. The temperature should be set at between 110°C - 130°C (230°F-266°F) depending on how the eggs need to be fried.
3. Care should be taken not to set the temperature too high as this causes 'blackening' of the eggs.
4. The unit has also been provided with a ball valve to allow for the draining of the oil.
5. Do not overfill the tank, as hot oil is extremely dangerous and can cause severe burns.

FTA 4400 – Egg Fryer

1. The Egg Fryer has a specially constructed tank fitted into the griddle plate surface.
2. The temperature of the oil can be thermostatically regulated between 60°C - 190°C (140°F - 374°F).

The remainder of the instructions are as per the FTA 1600 griller above.

FTA4600, FTA4600HK, FTA0900

1. FTA 4600, FTA4600 HK and FTA0900 grillers require a suitable single, two or three phase connection back to a distribution board. Please contact a qualified electrician for this installation. N.B. The FTA 4600 HK is fitted with two power-cords for connecting to 230VAC single-phase supply.
2. The 900mm griller (FTA 0900) is equipped with three thermostats. For accurate temperature control of the three heating zones, whilst the 600mm griller (FTA 4600) is fitted with two thermostats for the independent control of the two heating zones. The red pilots light will go out when the desired temperature is reached in each section.



TIP : COOKING AT A HIGHER TEMPERATURE
WILL NOT REDUCE YOUR COOKING TIME !
IT WILL PRODUCE UNSATISFACTORY RESULTS.

MODEL: 400mm EGG GRILLER	
MODEL CODE : FTA4400 R04	
Part No.	Description
1	BODY ASSEMBLY
2	THERMOSTAT
3	CONTROL PANEL FACIA
4	PILOT LIGHT
5	CONTROL KNOB
6	CONTROL PANEL INSERT
7	ANVIL AXIS LOGO
8	ELEMENT CLAMPING BRACKET
9	BOTTOM COVER
10	ELEMENT COVER
11	INSULATION PAD
12	ELEMENT
13	DRIP TRAY HOLDER
14	PERFORATED TRAY
15	ADJUSTABLE FEET
16	CABLE GRIP
17	POWER CORD
18	TERMINAL BLOCK
19	400MM EGG GRILLER TOP ASSEMBLY
20	1/4 BALL DRAIN VALVE

**EXPLODED DIAGRAM
400mm EGG FRYER 2kW
FTA4400 R04**

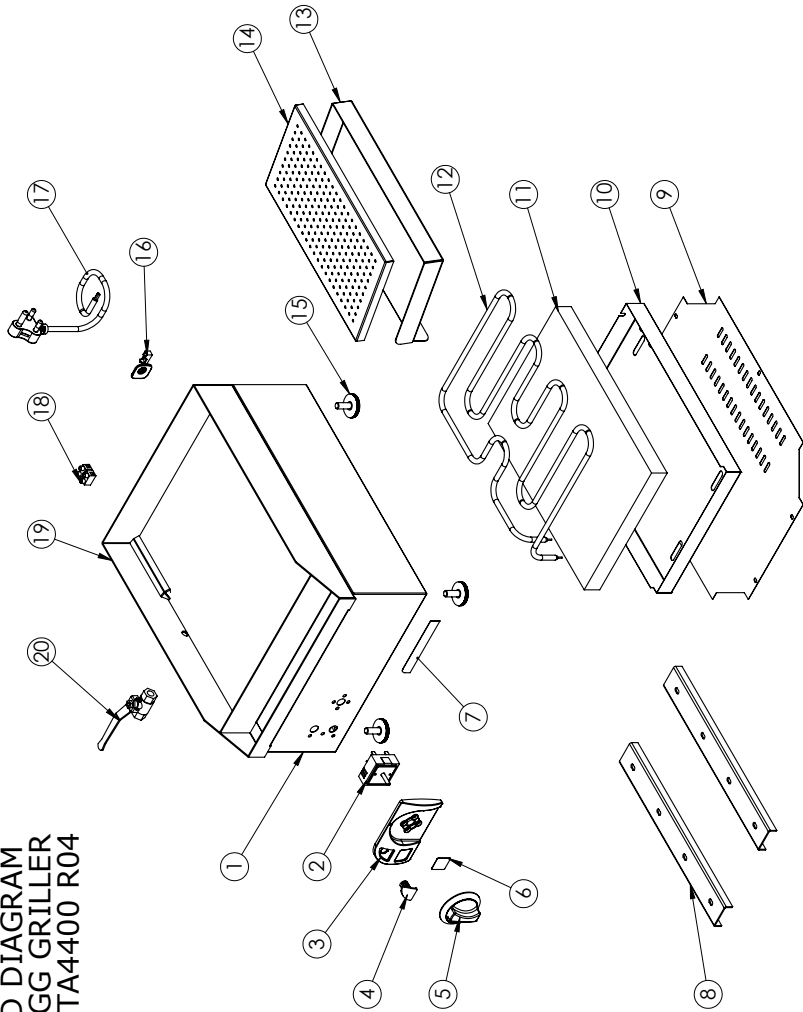

EXPLODED DIAGRAM
400mm EGG GRILLER
MODEL: FTA4400 R04



WARNING

Burn Hazard.

Do not touch hot food, liquid or heating surfaces while equipment is heating or operating

Hot surfaces and food can burn skin. Allow the hot surfaces to cool before handling

CLEANING

1. Always ensure that the unit is disconnected from the main power supply before cleaning.
2. The unit should not be cleaned with a water jet or immersed in water. Use only a damp cloth or sponge dipped in soapy water.
3. Always clean equipment thoroughly before first use. However, do not use chlorine or chloride – based products to clean the unit. These may lead to corrosion and pitting and will result in voiding the warranty on the unit.
4. Wipe off the unit with a dry cloth and wait at least half an hour before re – connecting to the main power outlet.



CLEAN THE STEEL PARTS WITH WATER AND SOAP. AVOID THE USE OF DETERGENTS CONTAINING ABRASIVE SUBSTANCES. ALWAYS RINSE WELL AND DRY CAREFULLY AFTER CLEANING. DO NOT USE PRODUCTS CONTAINING AGGRESSIVE CHEMICALS, ACIDS OR CHLORINE AS THIS WILL INVALIDATE THE WARRANTY



ALWAYS ENSURE THAT THE UNIT IS DISCONNECTED FROM THE MAIN SUPPLY BEFORE CLEANING



WARNING

Electric Shock Hazard.

Keep water and other liquids from entering the inside of the equipment. Liquid inside the equipment could cause an electrical shock

Do not spray water or cleaning products. Liquid could contact the electrical components and cause a short circuit or an electrical shock. Do not use equipment if power cord is damaged or has been modified

SAFETY

READ ALL INSTRUCTIONS BEFORE USE. FAILURE TO FOLLOW THESE PRECAUTIONS COULD RESULT IN INJURY TO YOURSELF AND OTHERS

1. When this appliances is to be positioned in close proximity to a wall, partitions, kitchen furniture, decorative finishes, etc. it is recommended that they be made of non-combustible material. If not, they shall be clad with a suitable non-combustible heat insulating material, and the closest attention be paid to fire prevention regulations.
2. Use the appliances on an individual 15A mains outlet only.
DO NOT OVERLOAD THE CIRCUIT.
3. Ensure that the equipment and the power supply cord does not come into contact with hot surfaces.
4. Supervision is necessary when the appliance is used in close proximity to children.
5. If the supply cord is damaged, it must be replaced with a new cord assembly available from the suppliers agent.
6. Use only earthed outlets matching the serial plate voltage.
7. Have equipment installed by a qualified personnel in accordance with local codes and ordinances.
8. Use equipment in a flat level position.
9. Do not operate unattended
10. The equipment may be hot, even though the pilot light is not on.
11. Do not operate if equipment has been damaged or is malfunctioning in any way.
12. These appliance sare designed to run only on alternating current (A.C.) **DO NOT CONNECT TO DIRECT CURRENT (D.C)**

600MM ELECTRIC GRILLER HALF RIBBED		
MODEL CODE : FTA2600 R03		
Part No.	SCE Part No.	Description
1	82-EG6-SS-BDYAS	BODY ASSEMBLY
2	1-EGO-150	GRILLER THERMOSTAT
3	1-PL-BMA0001	PILOT LIGHT
4	3-CPB-FTA0400	CONTROL KNOB
5	4-CPI-TEMP	FACIA PANEL INSERT
6	3-CPF-AXIS	CONTROL PANEL FACIA
7	82-EGC-SS-THAND	FAT TRAY
8	4-DL-L-AXIS	ANVIL AXIS LOGO
9	82-EGC-MS-ECBKT	ELEMENT CLAMP
10	82-NGC-SS-PCLMP	PROBE CLAMP
11	82-EG6-MS-BOTCV	BOTTOM COVER
12	82-EG6-MS-GECOV	ELEMENT COVER
13	3-25-INSU-GRILL	INSULATION PAD
14	5-1500W-GRILLER	GRILLER ELEMENT
15	11-DTF-FTA0400	FAT TRAY SHIELD
16	3-ADJ-PF	ADJUSTABLE FEET
17	2-PC-CE-CP	POWER CORD
18	3-CG-1.5	CABLE GRIP
19	3-FF-CB	TERMINAL BLOCK
20	82-EHR-SS-GTASS	600 GRIDDLE TOP HALF RIBBED

**EXPLODED DIAGRAM
FLAT TOP ELECTRIC GRILLER HALF RIBBED
FTA2600 R03**

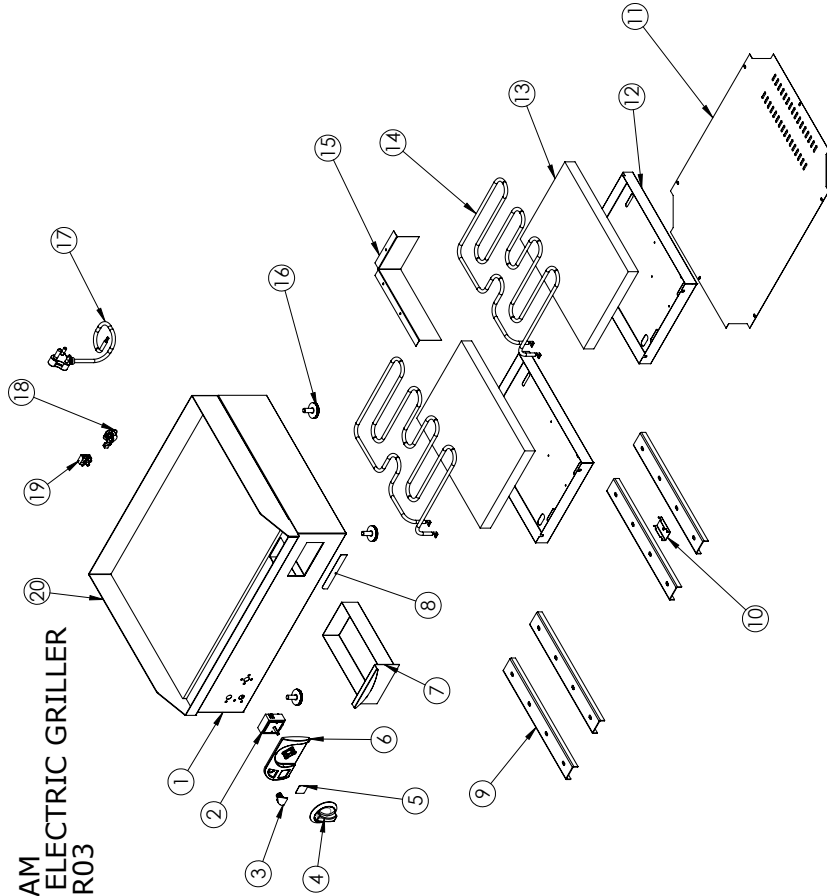

**EXPLODED DIAGRAM
600mm FLAT TOP ELECTRIC GRILLER
MODEL: FTA0600 R03**

**POSITIONING DIAGRAM
FLAT TOP EGG GRILLER ELECTRIC
FTA0400 R01/FTA1400 R01/FTA2400 R01
FTA4400 R02**

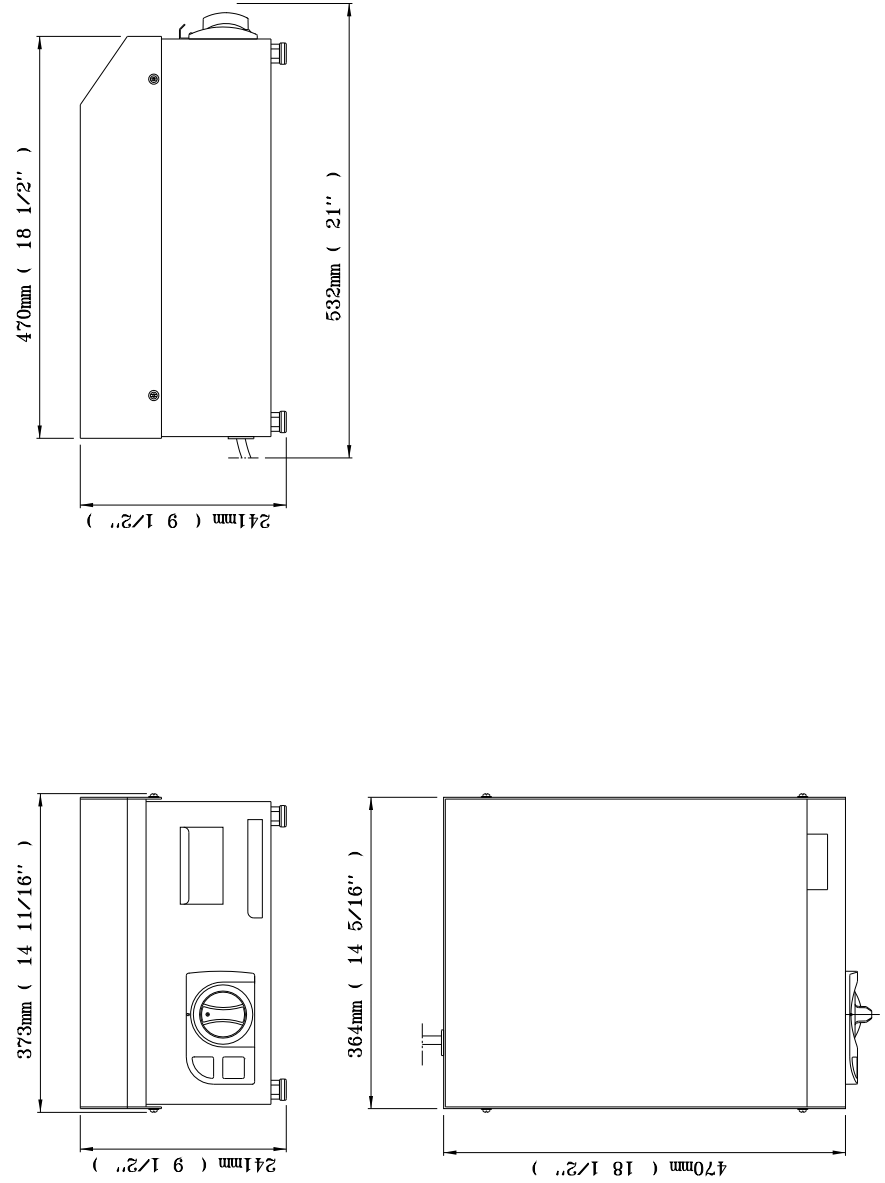

**POSITIONING DIAGRAM
FLAT TOP GRILLER ELECTRIC
FTA0600 R02/FTA2600 R01**

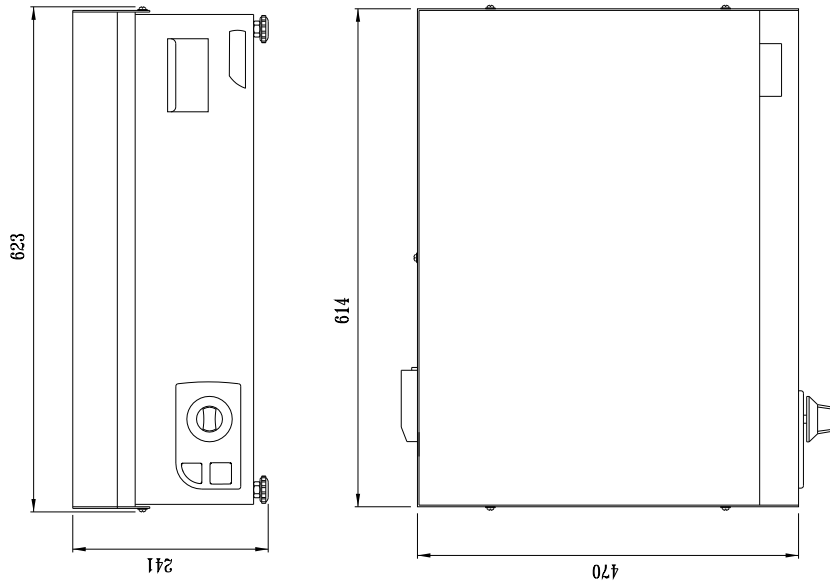
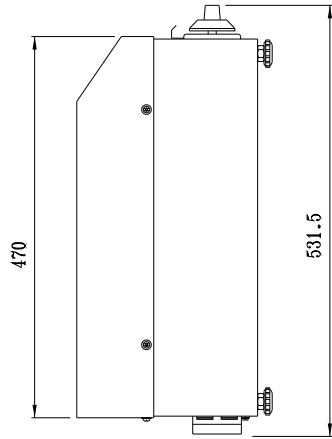

MODEL: EGG AND BACON GRILLER

MODEL CODE : FTA1600 R02

Part No.	Description
1	BODY ASSEMBLY
2	EGG GRILL CONTROL THERMOSTAT
3	CONTROL PANEL FACIA
4	PILOT LIGHT
5	CONTROL PANEL INSERT
6	CONTROL KNOB - EGG GRILL
7	CONTROL KNOB - BACON GRILL
8	BACON GRILL CONTROL THERMOSTAT
9	GRILLER FAT TRAY
10	ANVIL AXIS LOGO
11	ELEMENT CLAMP
12	PROBE CLAMP
13	BOTTOM COVER
14	ELEMENT COVER
15	INSULATION PAD
16	ELEMENT 1500W
17	FAT TRAY SHIELD
18	ADJUSTABLE PLASTIC FEET
19	CABLE GRIP
20	POWER CORD
21	TERMINAL BLOCK
22	EGG AND BACON TOP PLATE COMPLETE
23	1/4" BALL VALVE

**EXPLODED DIAGRAM
FLAT TOP EGG AND BACON GRILLER
FTA1600 R02**

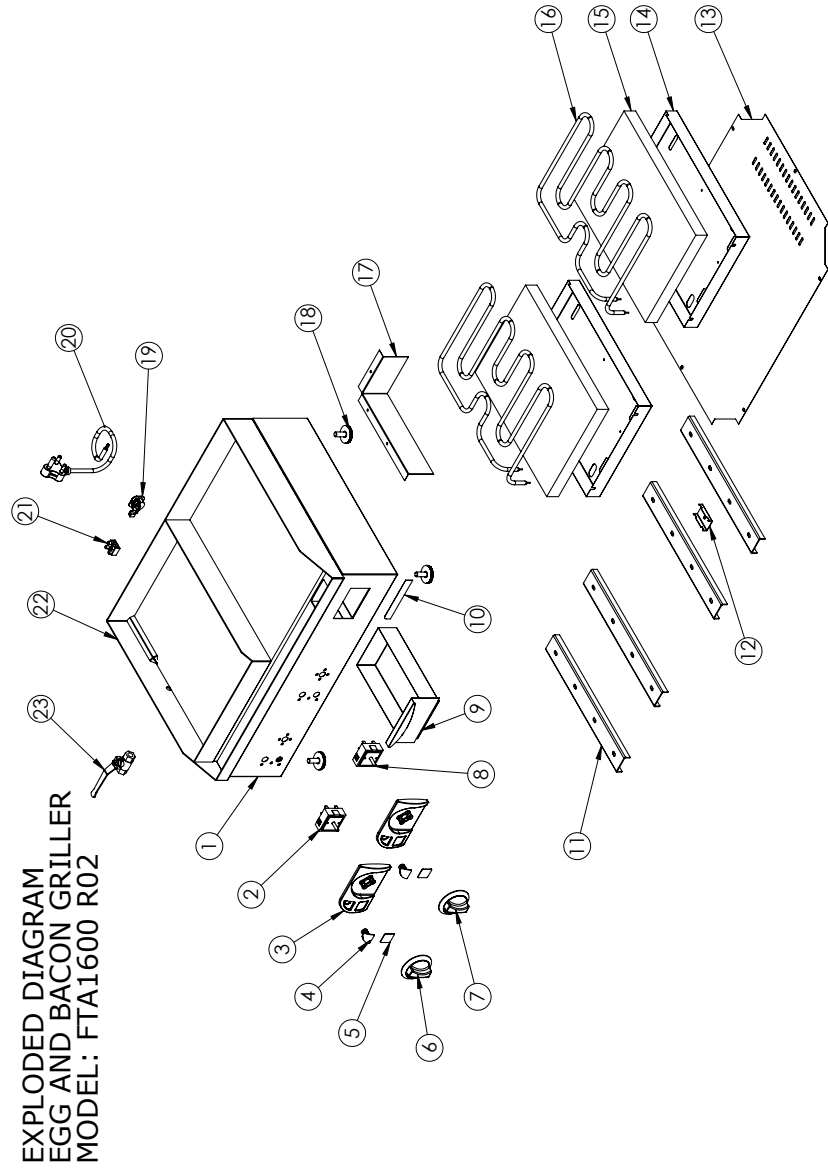

**POSITIONING DIAGRAM
FLAT TOP EGG AND BACON GRILLER
FTA1600 R01**

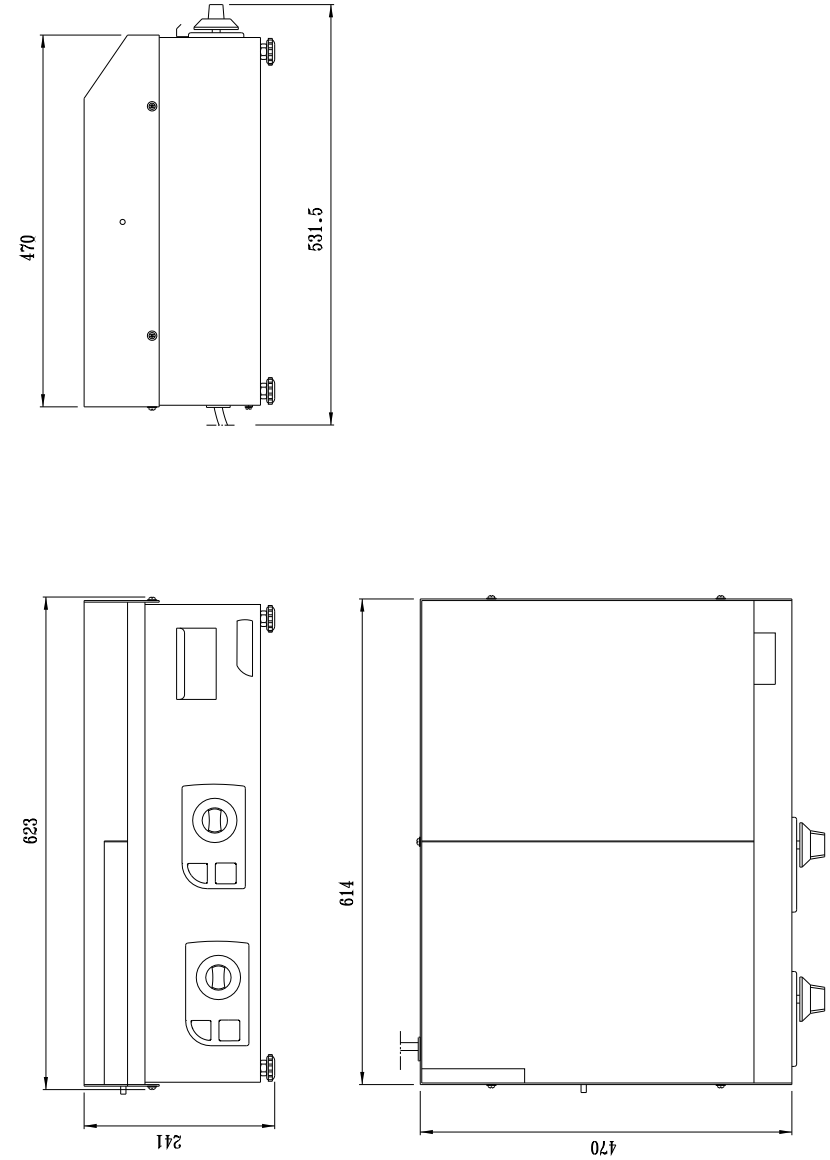

**EXPLODED DIAGRAM
EGG AND BACON GRILLER
MODEL: FTA1600 R02**

**POSITIONING DIAGRAM
FLAT TOP GRILLER
FTA0900 R01**

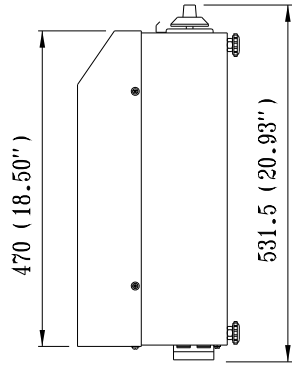

DIMENSIONS MM (INCHES)

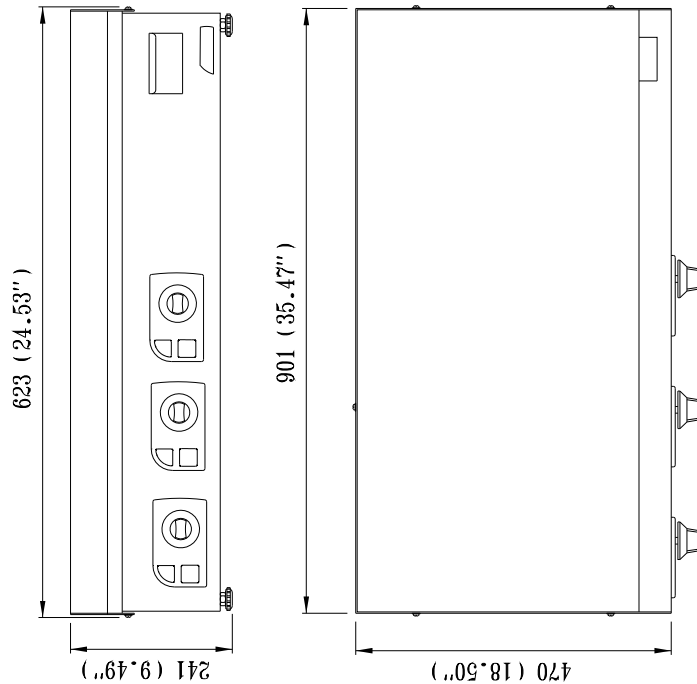

**900mm FLAT TOP ELECTRIC GRILLER
MODEL CODE : FTA0900 R02**

Part No.	Description
1	BODY ASSEMBLY
2	GRILLER THERMOSTAT
3	CONTROL PANEL FACIA
4	PILOT LIGHT
5	CONTROL KNOB
6	FACIA PANEL INSERT
7	FAT TRAY
8	ANVIL AXIS LOGO
9	ELEMENT CLAMP
10	PROBE CLAMP
11	BOTTOM COVER
12	ELEMENT COVER
13	INSULATION PAD
14	GRILLER ELEMENT
15	FAT TRAY SHIELD
16	ADJUSTABLE FEET
17	900 GRIDDLE FLAT TOP
18	3 PHASE CONNECTOR BLOCK

**EXPLODED DIAGRAM
FLAT TOP ELECTRIC GRILLER 2 PHASE
FTA0900 R02**

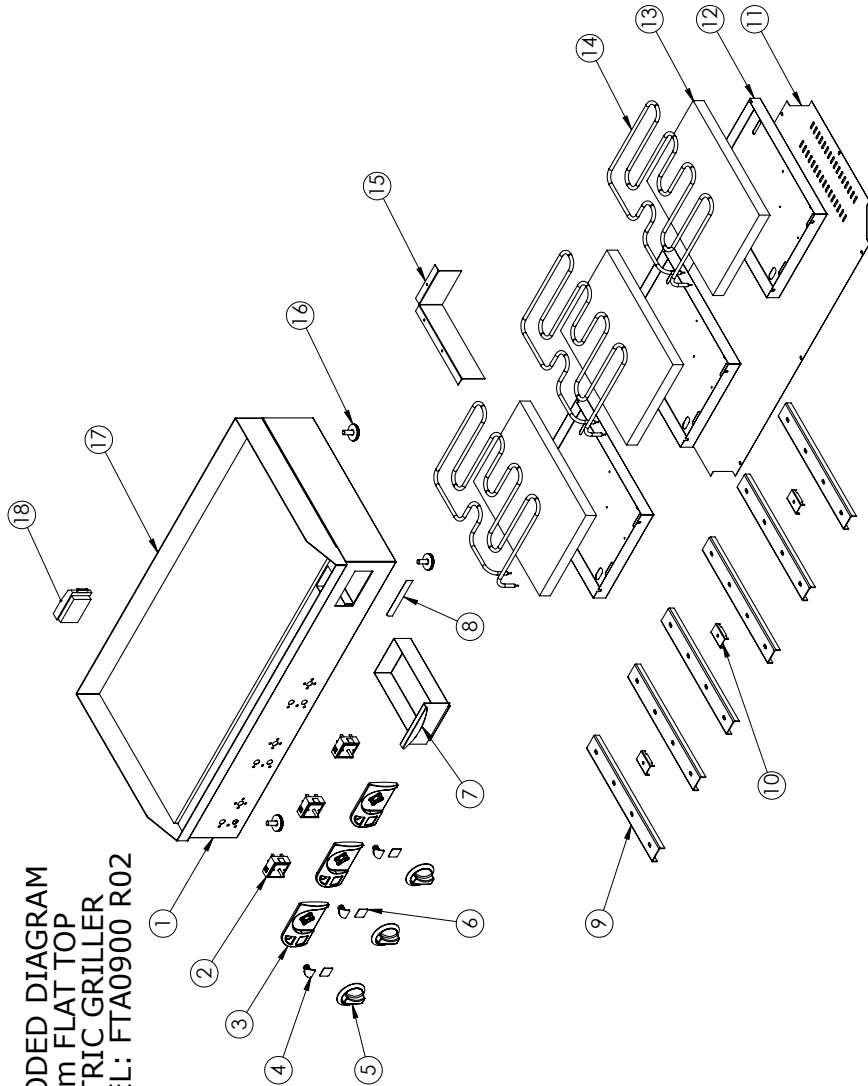

EXPLODED DIAGRAM
900mm FLAT TOP
ELECTRIC GRILLER
MODEL: FTA0900 R02

ELECTRICAL CONNECTION INFORMATION



IT IS ESSENTIAL TO MAKE SURE THAT THE INCOMING VOLTAGE IS THE SAME AS THE RATED VOLTAGE OF THE OF THE UNIT AS FOUND ON THE SERIAL PLATE. THE SERIAL PLATE IS LOCATED AT THE REAR OF THE UNIT ADJACENT TO THE INCOMING CABLE ENTRY.

**ELECTRICAL CONNECTION DIAGRAM (SCHEMATIC) FOR FTA0900
3 PHASE**

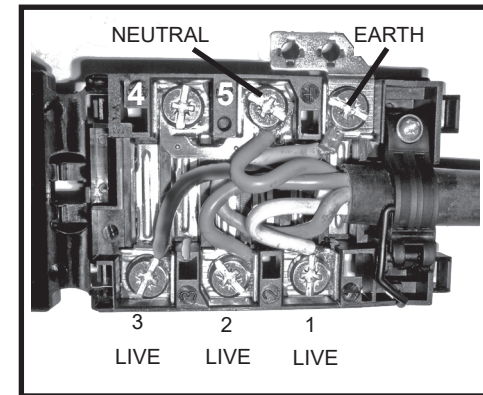

ELECTRICAL CONNECTION FOR FTA4600 2 PHASE

For 2 phase connection, connect live wires to terminals 1 and 2 as illustrated in above diagram

**WIRING DIAGRAM
FLAT TOP GRILLER
FTA0400 R01**

LEGEND	DESCRIPTION	PART NUMBER
B1	CONTROL THERMOSTAT	1-EGO-150
E1	GRILLER ELEMENT 2000W/230V	5-2000W-M/GRILL
H1	CONTROL PILOT LIGHT	1-PL-BMA0001

**WIRING DIAGRAM
FLAT TOP GRILLER
FTA0400 R01 -120V**

LEGEND	DESCRIPTION	PART NUMBER
B1	CONTROL THERMOSTAT	1-EGO-150
E1	GRILLER ELEMENT 1800W/120V	5-120V-1800W-GR
H1	CONTROL PILOT LIGHT	1-PL-BMA7102

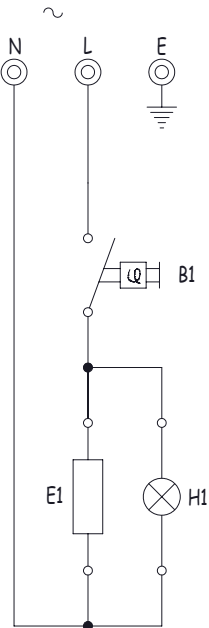

MODEL:600mm 2 PHASE ELECTRIC GRILLER

MODEL CODE : FTA0600 R03

Part No.	Description
1	BODY ASSEMBLY
2	GRILLER THERMOSTAT
3	PILOT LIGHT
4	CONTROL KNOB
5	FACIA PANEL INSERT
6	CONTROL PANEL FACIA
7	GRILLER FAT TRAY
8	ANVIL AXIS LOGO
9	ELEMENT CLAMP
10	PROBE CLAMP
11	BOTTOM COVER
12	ELEMENT COVER
13	INSULATION PAD
14	GRILLER ELEMENT
15	FAT TRAY SHIELD
16	ADJUSTABLE FEET
17	POWER CORD
18	CABLE GRIP
19	TERMINAL BLOCK
20	GRILLER TOP ASSEMBLY

**EXPLODED DIAGRAM
FLAT TOP ELECTRIC GRILLER
FTA0600 R03**

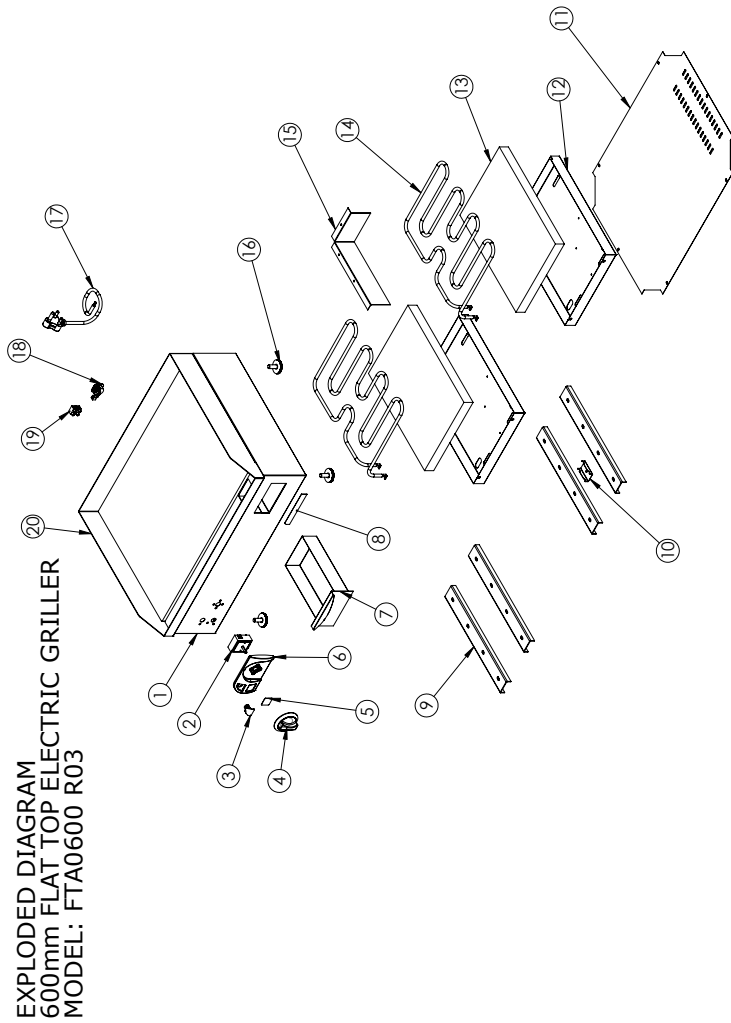

**WIRING DIAGRAM
400MM EGG FRYER
FTA4400 R02/FTA4400-120 R02**

LEGEND	DESCRIPTION	FTA4400	FTA4400-120
B1	CONTROL THERMOSTAT	1-THERM-FF-UL	1-THEM-FF-UL
E1	GRILLER ELEMENT 2000W/1800W	5-2000W-M/GRILL	5-120V-1800W-GR
H1	CONTROL PILOT LIGHT	1-PL-BMA0001	1-PL-BMA7102

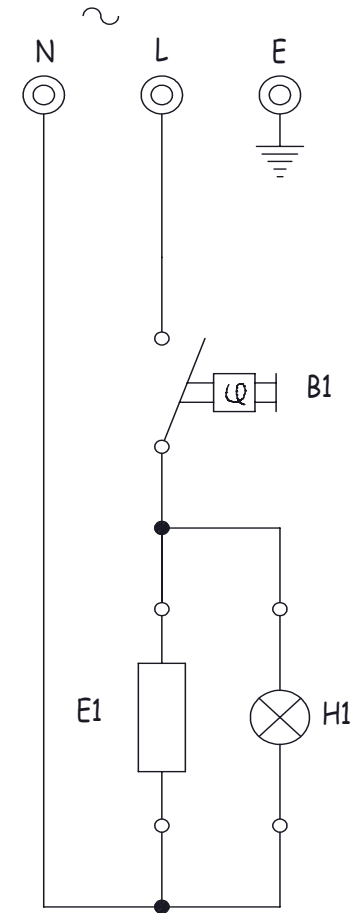

**WIRING DIAGRAM
FLAT TOP GRILLER
FTA0600 R02/FTA2600 R01**

LEGEND	DESCRIPTION	PART NUMBER
B1	CONTROL THERMOSTAT	1-EGO-150
E1/E2	GRILLER ELEMENT 1500W/230V	5-1500W-GRILLER
H1	CONTROL PILOT LIGHT	1-PL-BMA0001

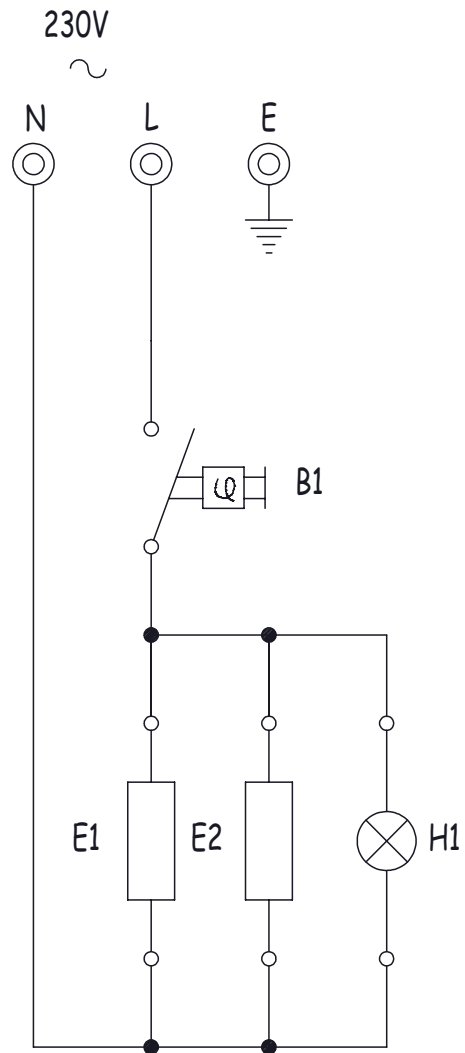

MODEL:400mm FLAT TOP ELECTRIC GRILLER

MODEL CODE : FTA0400 R03

Part No.	Description
1	BODY ASSEMBLY
2	GRILLER THERMOSTAT
3	CONTROL PANEL FACIA
4	PILOT LIGHT
5	KNOB
6	CONTROL PANEL INSERT
7	GRILLER FAT TRAY
8	ANVIL AXIS LOGO
9	ELEMENT CLAMPING BRACKET
10	PROBE CLAMP
11	BOTTOM COVER
12	GRILL ELEMENT COVER
13	INSULATION PAD
14	GRILLER ELEMENT
15	FAT TRAY SHIELD
16	ADJUSTABLE FEET
17	CABLE GRIP
18	POWER CORD
19	TERMINAL BLOCK
20	FLAT TOP PLATE ASSEMBLY

**EXPLODED DIAGRAM
400mm FLAT TOP ELECTRIC GRILLER
FTA0400 R03**

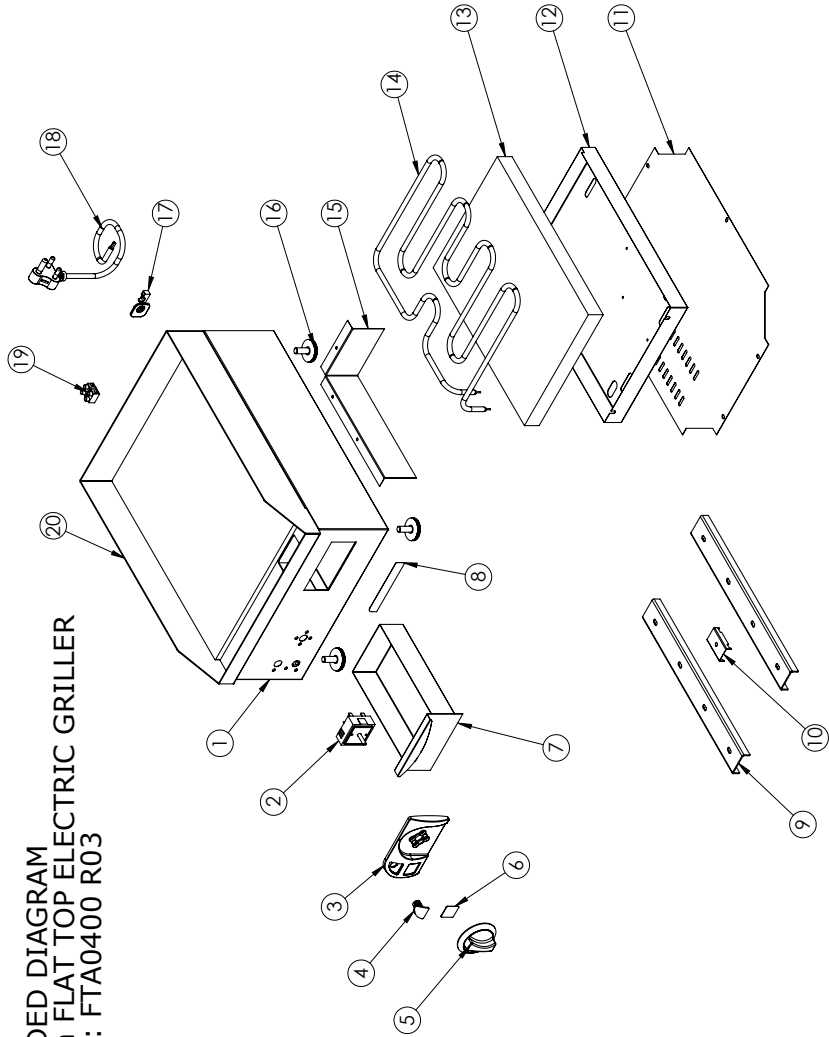

**EXPLODED DIAGRAM
400mm FLAT TOP ELECTRIC GRILLER
MODEL: FTA0400 R03**

**WIRING DIAGRAM
FLAT TOP GRILLER 6kW 2 PHASE
FTA4600 R01**

LEGEND	DESCRIPTION	PART NUMBER
B1	THERMOSTAT FOR CIRCUIT 1	1-EGO-150
B2	THERMOSTAT FOR CIRCUIT 2	1-EGO-150
E1	ELEMENT FOR CIRCUIT 1 2800W/230V	5-2800W-GRILL
E2	ELEMENT FOR CIRCUIT 2 2000W/230V	5-2800W-GRILL
H1	PILOT LIGHT	1-PL-BMA0001
H2	PILOT LIGHT	1-PL-BMA0001

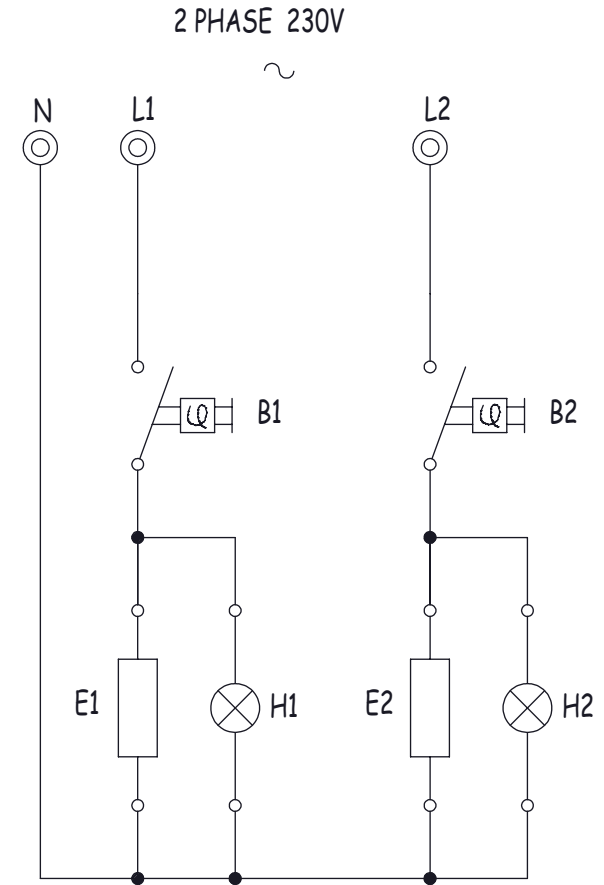

**WIRING DIAGRAM
FLAT TOP GRILLER BACON AND EGG
FTA1600 R01**

LEGEND	DESCRIPTION	PART NUMBER
B1	CONTROL THERMOSTAT	1-THERM-FF-UL
B2	CONTROL THERMOSTAT	1-EGO-150
E1	GRILLER ELEMENT 1500W/230V	5-1500W-GRILLER
E2	GRILLER ELEMENT 1500W/230V	5-1500W-GRILLER
H1	PILOT LIGHT	1-PL-BMA0001
H2	PILOT LIGHT	1-PL-BMA0001

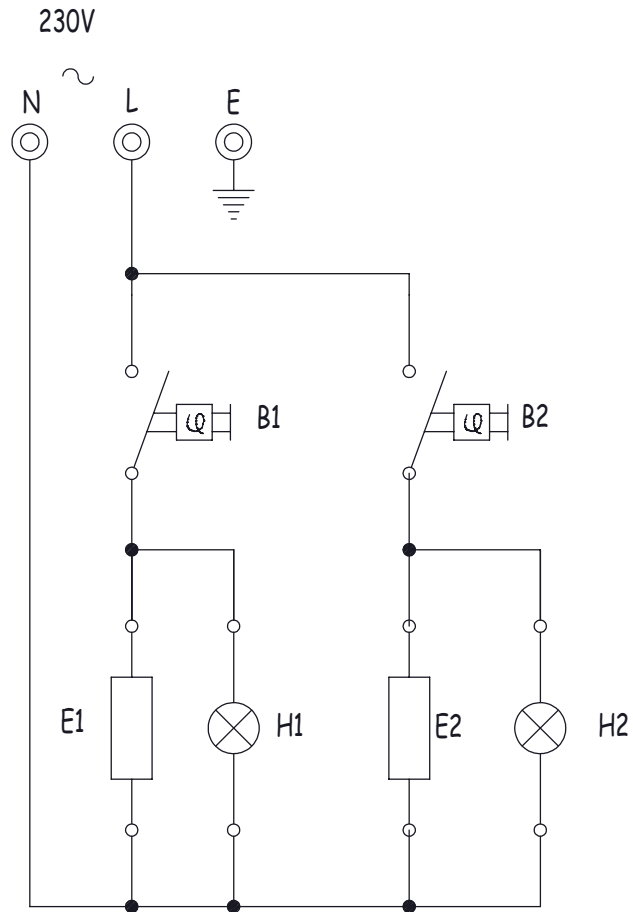

**WIRING DIAGRAM
FLAT TOP GRILLER
FTA0900 R01**

LEGEND	DESCRIPTION	PART NUMBER
B1	CONTROL THERMOSTAT FOR CIRCUIT 1	1-EGO-150
B2	CONTROL THERMOSTAT FOR CIRCUIT 2	1-EGO-150
B3	CONTROL THERMOSTAT FOR CIRCUIT 3	1-EGO-150
E1	ELEMENT FOR CIRCUIT 1 2800W/230V	5-2800W-GRILL
E2	ELEMENT FOR CIRCUIT 1 2800W/230V	5-2800W-GRILL
E3	ELEMENT FOR CIRCUIT 1 2800W/230V	5-2800W-GRILL
H1	PILOT LIGHT	1-PL-BMA0001
H2	PILOT LIGHT	1-PL-BMA0001
H3	PILOT LIGHT	1-PL-BMA0001

