

CONVECTION OVEN PRIMA LITE

MANUFACTURING
SINCE 1966



Model: COA1001



FEATURES

- Stainless Steel exterior and interior
- Rounded interior corners and removable shelf runners ensure ease of cleaning
- The oven is fitted with one fan and a custom designed baffle plate. This ensures that excellent temperature distribution is achieved providing a reliable baking uniformity and a product which is perfectly baked on both sides making it superior to static ovens
- A bake timer is also included to automatically switch off after a preset period
- Interior light is fitted as a standard feature
- Operating temperature: 50°C - 300°C
- New single cam hinge design with fewer wearing parts
- Modern style glass door
- Easily removable inner glass for cleaning
- Modern style full width glass door

NOTE:

- 3 x Chrome Grids
- Timer Function Included



ALL ANVIL EQUIPMENT COMES WITH A TWO YEAR WARRANTY ON COMPONENTS AND DEFECTIVE WORKMANSHIP.

www.anvilworld.com

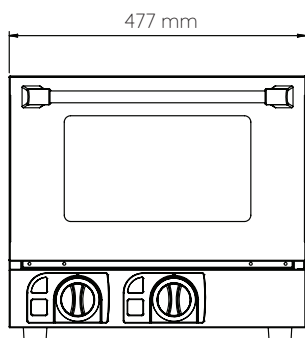
Model: COA1001

SPECIFICATIONS

POWER	1.2kW
VOLTAGE	230V - 50Hz
PACKAGING (W x D x H)	560 x 570 x 450 (mm)
UNIT (W x D x H)	477 x 524 x 428 (mm)
CHAMBER DIMENSIONS	350 x 260 x 218 (mm)
NET WEIGHT	16kg
GROSS WEIGHT	18kg
SHIPPING VOLUME	0.14m ³
RUNNER SPACE	40 - 70mm
FAN	1 Fan

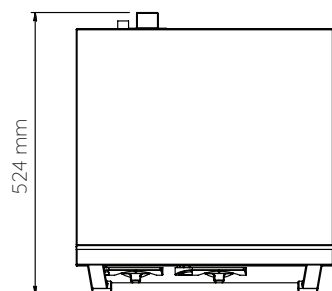
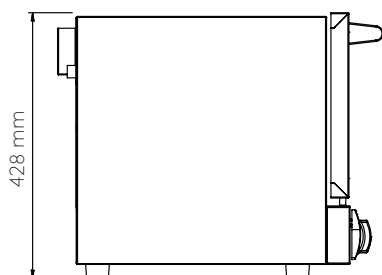
AVAILABLE IN

 120V/60Hz

NOTE

- When viewing the appliance from the front in its usual operating position, the width (W) of the product is the total distance from left to right; the depth (D) of the product is the total distance from the front to the back; the height (H) is the total distance from the bottom of the product to the top. Pictures may vary from actual product.

DISCLAIMER

- Output performance figures quoted are dependent on various factors. Anvil reserves the right, without notice, to make changes and revisions to product specifications, materials and design, when we believe it will provide better performance, durability, and efficiency. Unit measurements may vary depending on point of reference.



ALL ANVIL EQUIPMENT COMES WITH A TWO YEAR WARRANTY ON COMPONENTS AND DEFECTIVE WORKMANSHIP.

www.anvilworld.com