

CONVECTION OVEN 6 PAN

MANUFACTURING
SINCE 1966



Model: COA2006-R01



FEATURES

- 12kW 3 Phase oven
- 250°C Thermostat
- Capacity for 6 baking trays 600mm wide , or 6 gastronorm dishes
- 80mm spacing between shelves
- Large single capacity powerful circulating fan
- Semi automatic steam control via energy regulator
- Slam shut door with a 2 stage release function
- Full glass viewing door
- Push button operation
- Rapid heating
- Excellent heat distribution and airflow
- Fast cooking and Recovery time
- Perfect for meat, vegetables and baked products
- Compact modern design, easy to operate

NOTE:

- 2 x Chrome Grids Included



ALL ANVIL EQUIPMENT COMES WITH A TWO YEAR WARRANTY ON COMPONENTS AND DEFECTIVE WORKMANSHIP.

www.anvilworld.com

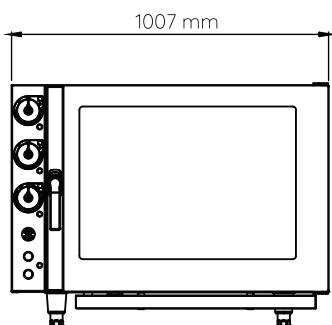
Model: COA2006-R01

SPECIFICATIONS

POWER	12kW
VOLTAGE	380V - 50Hz - 3Phase
PACKAGING (W x D x H)	1033 x 1113 x 1044 (mm)
UNIT (W x D x H)	1007 x 1060 x 856 (mm)
CHAMBER DIMENSIONS	702 x 570 x 628 (mm)
RUNNING SPACE	80mm
NET WEIGHT	124kg
GROSS WEIGHT	152kg
SHIPPING VOLUME	1.2m ³
SHELF CAPACITY	6

AVAILABLE IN

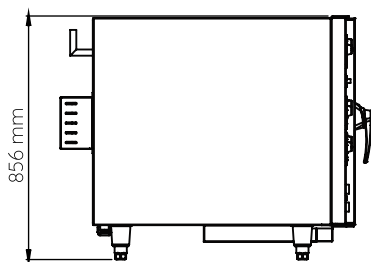
 380V/60Hz

NOTE: This oven is for industrial use.

OPTIONAL EXTRAS
TRAYS

CODE	DESCRIPTION
COR3001	Chrome Grid
COR3003	Baking Tray - Perforated
BTA0011	Baking Tray - Aluminum

STANDS

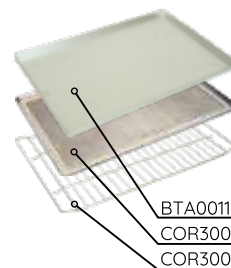
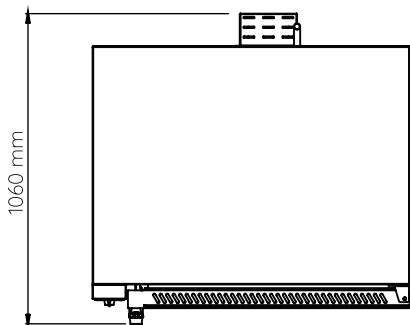
CODE	DESCRIPTION
COA1011	Stand

NOTE

- When viewing the appliance from the front in its usual operating position, the width (W) of the product is the total distance from left to right; the depth (D) of the product is the total distance from the front to the back; the height (H) is the total distance from the bottom of the product to the top. Pictures may vary from actual product.

DISCLAIMER

- Output performance figures quoted are dependent on various factors. Anvil reserves the right, without notice, to make changes and revisions to product specifications, materials and design, when we believe it will provide better performance, durability, and efficiency. Unit measurements may vary depending on point of reference.

ALL ANVIL EQUIPMENT COMES WITH A TWO YEAR WARRANTY ON COMPONENTS AND DEFECTIVE WORKMANSHIP.
www.anvilworld.com