

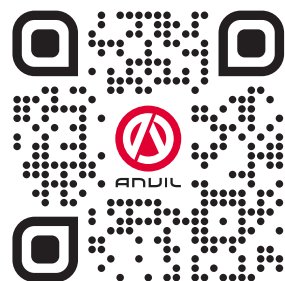

ANVIL

Installation, Operation and Care Manual



SCAN ME
TO GO TO
WARRANTY
REGISTRATION

MANUFACTURING
SINCE 1966

4-INS-TSA9209

THE CHEFS COMPANION

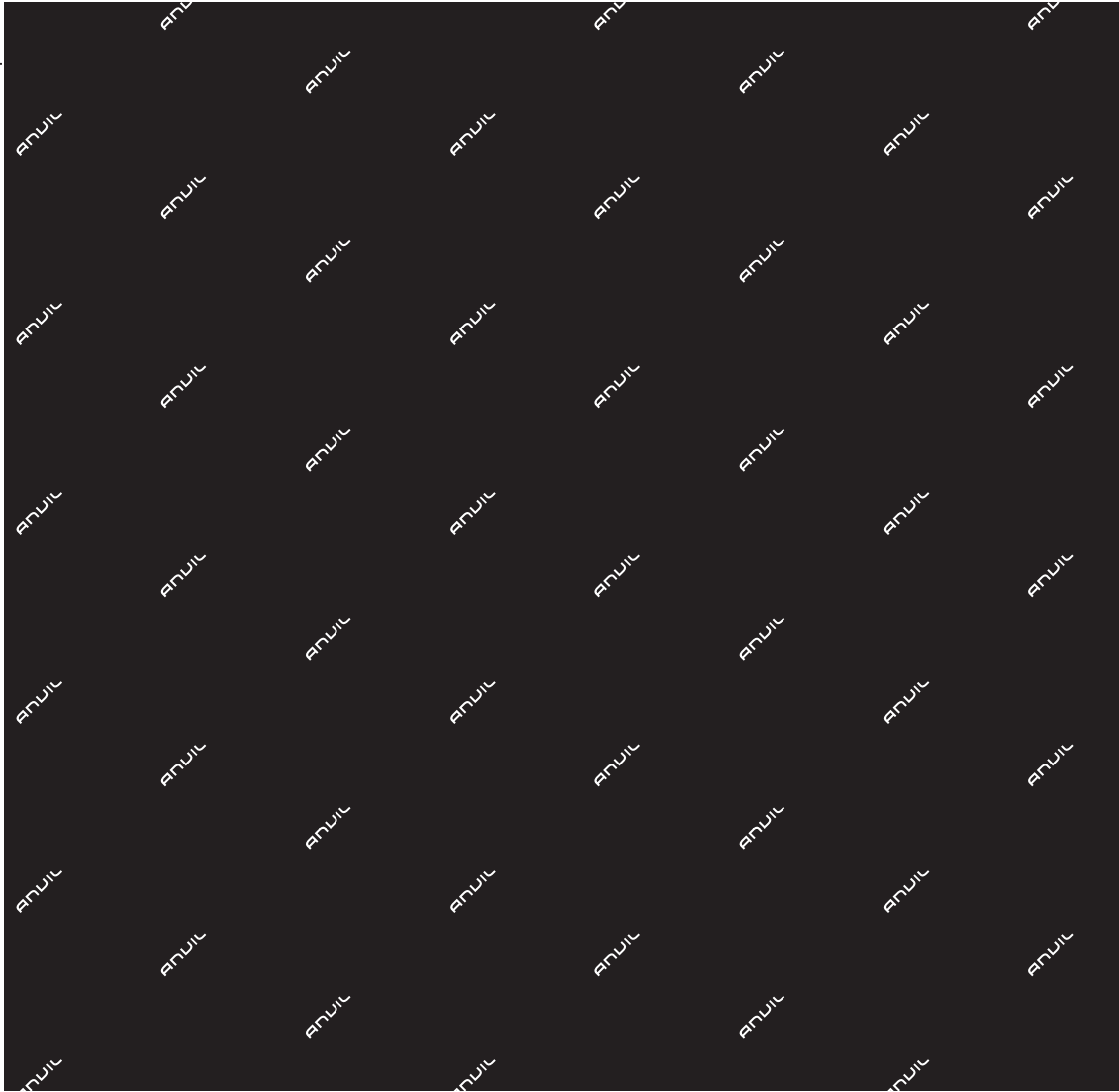

THE CHEFS COMPANION



THANK YOU FOR PURCHASING AN ANVIL PRODUCT!



REGISTER ONLINE TODAY

Register your warranty on-line at www.anvilworld.com today and learn how to get the best out of your Anvil product, tips to care for your Anvil product for long lasting performance, exciting recipes and more.

NO WEB ACCESS?

If you do not have access to the Web, register by completing this form and faxing it to the Anvil head office in South Africa. Fax: +27 11 474 1630

ONLY COMPLETE IF YOU DO NOT HAVE WEB ACCESS

Company _____

Name _____

Surname _____

Telephone _____

Cellphone _____

Email Address _____

Country _____

Postal address _____

Anvil products purchased _____

Code (see box label) _____

Serial number (see back of machine) _____

INTENDED USE

- Full-Service restaurant
- Coffee Shop / Deli
- Fast Food Outlet
- Hotel
- Bed & Breakfast
- School Cafeteria

- Institutional Cafeteria
- Corporate Catering
- Private Use
- Franchisor
- Convenience Store
- Other

 ALL ANVIL EQUIPMENT COMES WITH A TWO YEAR WARRANTY ON COMPONENTS AND DEFECTIVE WORKMANSHIP.

www.anvilworld.com

LIMITED WARRANTY

All equipment which is sold under ANVIL trademark and used for commercial purposes is warranted against defects in materials and workmanship. The warranty runs for two years from the date of original installation and is for the benefit of the original purchaser only. All other Warranties, expressed or implied, statutory or otherwise, including without limitations any implied Warranty of Merchantability or fitness for purpose are excluded. The Seller shall in no event be liable for direct, indirect or consequential damages in connection with ANVIL commercial products.

The Sellers obligation under this Warranty is limited to the repair of defects without charge. Defective units must be taken or shipped, transportation charges prepaid, to ANVIL.

This Warranty is not effective if damage occurs because of accident, carelessness, improper installation, lack of proper set-up, supervision when required or if the equipment is installed or operated in any manner contrary to the installation and operating instructions. In these cases, repairs will be made at a reasonable cost. Work performed by unauthorized personnel or unauthorized service agencies using non Anvil spares voids this Warranty.

9 SLICE GAS TOASTER

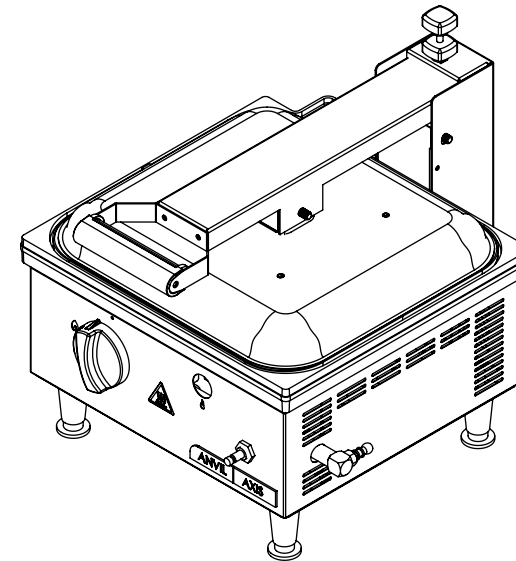

NB:

REGISTER ON-LINE TODAY

Register your warranty on-line now at www.anvilworld.com

NO WEB ACCESS

If you do not have access to the Web. Kindly register by completing the warranty registration form and fax it to the ANVIL office in the country of purchase.

Failure to do so will invalidate your warranty.

**INSTALLATION OPERATION AND CARE OF
9 SLICE GAS TOASTER
MODEL: TSA9209**

UNPACKING

Unpack the product and check for any damage incurred during transit. This should be reported to the responsible carrier, railway or postal authority, and a request for a damage report should be made.



THESE INSTRUCTIONS MUST BE FOLLOWED FOR US TO GUARANTEE OUR FULL SUPPORT OF YOUR CLAIM FOR PROTECTING AGAINST LOSS FROM CONCEALED DAMAGE. THE FORM FOR FILING SUCH A CLAIM WILL BE PROVIDED BY THE CARRIER.

These appliances are intended for use with LPG at a pressure of 2.8kPa.

Regulators used with this appliance must comply to SANS 1237 and be approved by the LPGASA. Only regulators certified for operation at 2.8kPa must be used on these appliances.

GENERAL INSTALLATION AND OPERATION INSTRUCTIONS

1. This appliance should only be used in a WELL – VENTILATED ROOM. Adequate ventilation allows for the removal of the products of combustion and allows the entry of replacement air.
2. This appliance has a factory set fixed primary air intake and no adjustment is necessary. No adjustments to jets or air intakes should be undertaken unless carried out by a factory approved agent.
3. The Installation of appliances may only be carried out by a registered installer and such installations shall comply with the requirements of SANS 10087-1
4. Make sure that all connections are gas tight by brushing with a soapy water or liquid detergent (a gas leak will form bubbles). If bubbles form, close cylinder valve and hand tighten all fittings again. IF BUBBLES STILL FORM, DO NOT USE THE APPLIANCE. Have a dealer check the unit.
5. This toaster is for general purpose kitchen use and is ideal for browning, melting cheese and various toasting functions.
6. The 9 Slice gas toaster is designed for optimum heat on the bottom plate, turning of product may be necessary to achieve even cooking on both sides.

NOTES:



THIS APPLIANCE MUST NOT BE USED IN BASEMENTS OR IN ROOMS LESS THAN 15 CUBIC METRES IN VOLUME. (TYPICALLY 2.6M SQUARE)

7. To ignite the burner a long shaft lighter must be used, the hole on the body indicates where the burner is situated for ignition.
8. When igniting the burner, turn the burner control knob to the 'HI' position. Press in the shaft on the flame failure and ignite the burner. Thereafter set the burner control to the desired heat between 'LO' and 'HI' on the scale. Should the flame for any reason be extinguished unintentionally the flame failure valve will automatically cut off the gas supply to the burner after approx 30 secs.
9. In the event of burn back, where the flame burns back and ignites at the jet, immediately turn off the gas supply by first closing the control valve on the gas cylinder and then the appliance valve. After the flame is extinguished, remove the gas regulator and check the condition of its seal, and if necessary replace the seal. Should the flame light back persistently, return the product to your authorized ANVIL repair agent.
10. To re-light the burner, follow the procedure as in paragraph 7 and 8 above.
11. Before cooking with the appliance for the first time, turn the controls to the maximum heat and allow the unit to BURN IN for approximately 20 minutes. You will notice smoke appearing due to the protective coating burning off. THIS IS NORMAL.
12. After the burn-in time has elapsed, turn the control valve knobs down to the required operating setting.
13. To switch off this appliance, turn the control knobs to the 'OFF' position and close the valve on the gas cylinder by turning the hand wheel in a CLOCK WISE direction.

MAINTENANCE

There are no predetermined maintenance intervals for this appliance however the following should be observed.

1. Inspect hoses and replace if they are not in order, before using the appliance as cracked and perished hoses can be dangerous replace if necessary with hoses as detailed in point 5.
2. Allow the appliance to cool sufficiently before attempting any maintenance.
3. The appliance is fitted with a jet to regulate the correct amount of gas. The small hole in the jet may become blocked, resulting in a small flame or no flame on the burner. To clean, unscrew it from the appliance Clean the jet by blowing the hexagon end, or by using a jet cleaner. Do NOT attempt to clean the jet with a sharp object, as this will damage the very small jet aperture and cause the appliance to malfunction. If the jet still does not function, replace it with a new jet of the correct size. To re-assemble, reverse the above procedures. The same procedure applies if the pilot burner jet becomes blocked
4. Check that the flexible hose is completely connected over the nozzles at each end of the tubing and that it is held firmly in place by hose clamps. Examine the flexible hose regularly, at least each time the gas cylinder is changed and ask your dealer to fit a new LPG hose if it becomes perished, worn or damaged.
5. Only LPG hose that complies with SANS 1156-2 or BS 3212 may be used with this appliance.

6. Trouble Shooting

- A normal flame is blue and may have an orange or yellow tip. If the flame is completely yellow, it may be that the jet is not securely fitted. Re-tighten to give a gas tight seal. An over-filled gas cylinder can also cause large yellow flames. Cylinder should be returned to filling station and checked by weight.
- Check that the primary air supply apertures in the burners are clear and free of obstructions.
- If the flame power drops or the gas will not light, check that the gas cylinder still contains gas (shake to hear the noise made by the liquid). If there is still gas, the jet might have become blocked or partially blocked.
- If you suspect a blocked jet, follow the instruction in Section 3 above.

MODEL: 9 SLICE PANINI NON-STICK GAS TOASTER
MODEL CODE : TSA9209
REV.1

Part No.	SCE Part No.	Description
1	3-KNOB-TOAST	HANDLE ADJUSTING SCREW
2	82-ARM-SS-HPOST	HANDLE HINGE BRACKET
3	82-ARM-SS-HFSHD	HANDLE FRONT SHIELD
4	7-PANINI-SPRING	HANDLE SPRING
5	14-M5/50-EB-MS	M5 PLATED EYE BOLT
6	7-PAN-BOTTOM-1	ALUMINIUM BOTTOM CASTING
7	82-ARM-MS-SSBKT	SPRING BRACKET
8	7-FCUP-TOASTER	DRIP CUP
9	3-GH-FFA3010	8MM GAS HOSE 1 METER LENGTH
10	7-BNR-LPG	BULL NOSE REGULATOR
11	82-TSG9-SS-BDYAS	BODY ASSEMBLY
12	7-FOOT-FTA7016	GRILLER ADJUSTABLE FOOT CASING
13	82-TSG9-MS-BOTCV	BOTTOM COVER GALVANISED
14	82-TSG9-HSHLD	BURNER HEAT SHIELD
15	4-DL-L-AXIS	DOMED LOGO LARGE ANVIL AXIS
16	82-TSG9-SS-BBKT	BURNER BRACKET
17	7-CS-TSA9209	COOLING SPACER
18	7-BURNER-TSA9209	TSA9209 U BURNER
19	7-MAN-TSA9209-A	INLET MANIFOLD
20	7-SV-GGA0004	SAFETY VALVE GGA0004
21	82-NGC-SS-MCLMP	MANIFOLD CLAMP
22	3-KNOB-APEX	CONTROL KNOB APEX
23	3-KI-APEX	CONTROL KNOB INSERT FOR GAS VALVE
24	7-MAN-TSA9209-B	FRONT CROSS MANIFOLD
25	7-CV-GGA0004	CONTROL VALVE GGA0004
26	7-JET-TSA9209-LPG	JET
27	7-TC-GGA0004	THERMOCOUPLE GGA0004
28	7-REG-ADP	ANGLE GAS PIPE BRASS CONNECTOR
29	3-TOASTER-HAND	PLASTIC TOASTER HANDLE
30	82-ARM-SS-HAFRT	STAINLESS STEEL HANDLE
31	82-ARM-SS-ASSEM	9 SLICE TOASTER ARM
32	6-TOASTER-HS	TOP HINGE AXLE M8
33	81-TS9-9S-LID	PRESSED TOASTER STAINLESS STEEL LID
34	6-TOASTER-LS	M5 HEX SPACERS
35	7-PAN-TOP-1	ALUMINIUM TOP CASTING PANINI

**EXPLODED DIAGRAM
9 SLICE GAS TOASTER
TSA9209 R00**

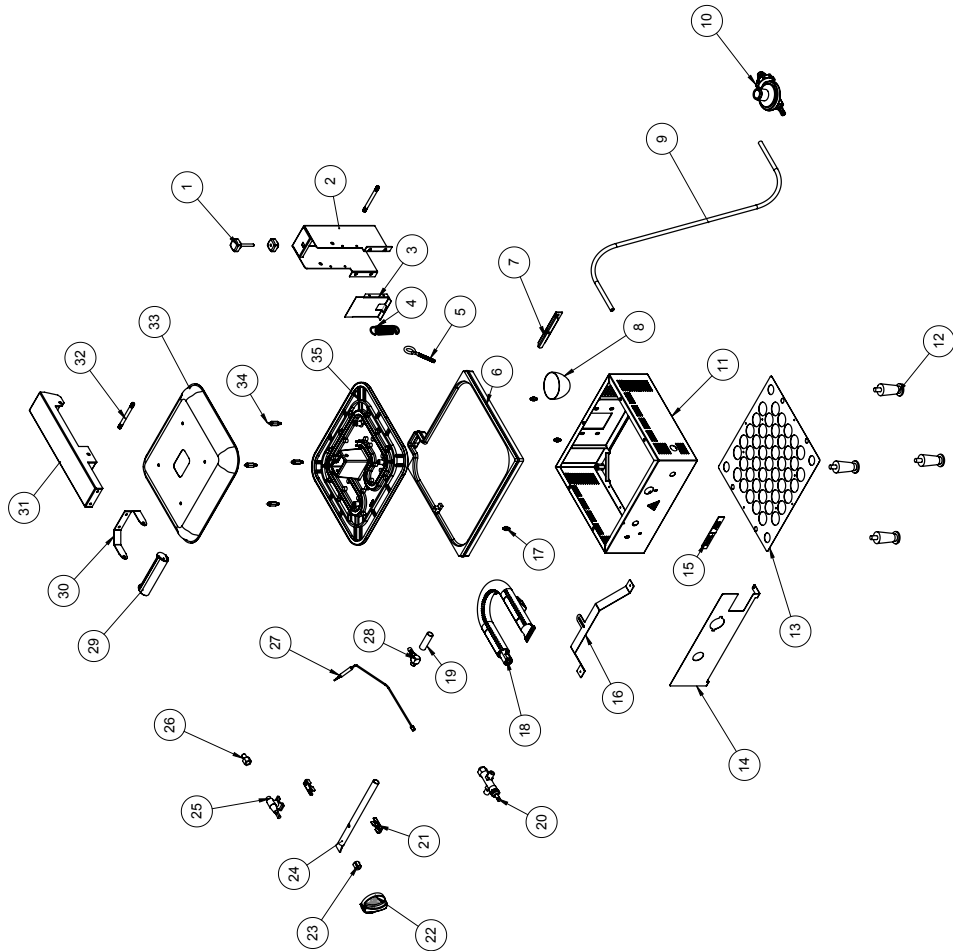

DESCRIPTION OF MODELS

MODEL	DESCRIPTION	BURNERS	POWER (BTU)
TSA9209	9 SLICE GAS TOASTER	1	7000

EMERGENCY DRILL:

It is recommended that commercial kitchens have a suitable placed and sized fire extinguisher.

NOTE: Keep kitchen clean, particularly from fatty build up, especially in the vent ducting, as this is frequently the point of ignition.

IF YOU SHOULD SMELL GAS:

- * Turn off gas supply at cylinder.
- * DO NOT switch electrical equipment ON or OFF
- * Open all doors and windows to increase ventilation.
- * Extinguish open flames
- * Move cylinder outside if safe
- * Look for leaks with soapy water
- * No smoking

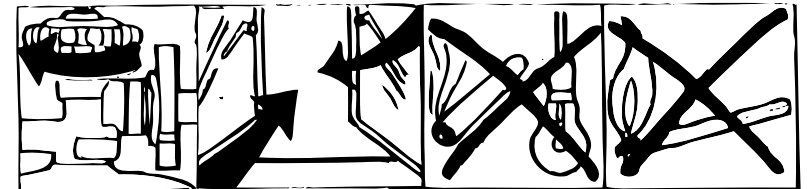

IMPORTANT INFORMATION FOR THE USER

This appliance may only be installed by a registered LP Gas installer. All registered installers are issued with a card carrying their registration number. Ask to be shown the card before allowing the installation to commence and make a note of the Installer QCC number. Upon completion of the installation, the installer is required to explain the operational details of the appliance together with the safety instructions. You will be asked to sign acceptance of the installation and be provided with a completion certificate and should only sign acceptance of the Installation when the installation is completed to your satisfaction. Note that your invoice is required in the event that you wish to make a guarantee claim.

IMPORTANT INFORMATION FOR THE INSTALLER

This appliance may only be installed by LP gas installer registered with the LPGASA .The appliance must be installed with the requirements of SANS10087-1 and any fire department regulation and/or local bylaws applicable to the area. If in doubt check with the relevant authority before undertaking the installation. Upon completion of the installation you are required to fully explain and demonstrate to the user the operational details and safety practises applicable to the appliance and the installation.

FIRE AT CYLINDERS

(A) Don't panic - Flames from joints near a cylinder are not dangerous in themselves, as long as they do not heat up the cylinder.

(B) If possible, close the cylinder valve using a wet cloth to protect your hand.

(C) Spray cold water onto cylinders exposed to the fire in order to keep them cool. Use a hose pipe. Keep people away from the area.

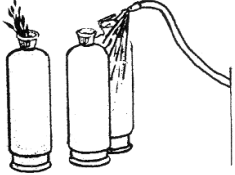

POSITIONING DIAGRAM 9 SLICE GAS TOASTER TSA9209 R00

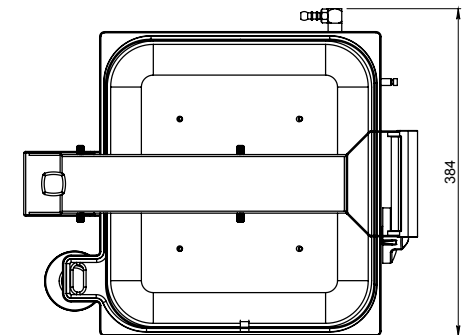
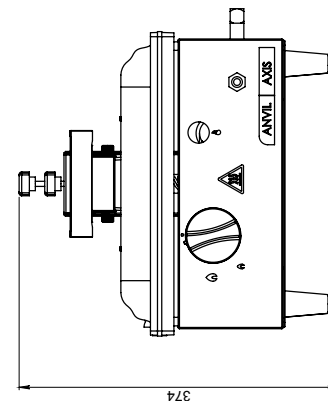
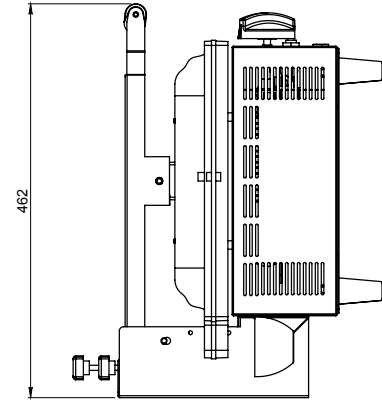

SAFETY:**READ ALL INSTRUCTIONS BEFORE USE. FAILURE TO FOLLOW THESE PRECAUTIONS COULD RESULT IN INJURY TO YOURSELF AND OTHERS**

1. When this appliance is to be positioned in close proximity to a wall, partitions, kitchen furniture, decorative finishes, etc. it is recommended that they be made of non-combustible material. If not, they shall be clad with a suitable non-combustible heat insulating material, and the closest attention be paid to fire prevention regulations.
2. Do not use an appliance that is damaged, leaking or which does not operate properly.
3. Ensure that the gas cylinder is connected or changed in well ventilated area, preferably outdoor, away from any source of ignition as open flames, and away from other people.
4. Keep gas cylinder away from heat and flames. Do not place on a stove or any other hot surface.
5. Ensure that the assembled unit is stable and does not rock.
6. Do not cover or change the primary air supply apertures in the burner as this will affect the performance of the product and may lead to unstable flames.
7. If there is a leak on the appliance (smell of gas), turn off the gas supply, first at the control valve on the cylinder and then on the appliance by turning the control knobs fully clockwise.
8. If you wish to check for leaks on your appliance, do it outside. Do not try to detect leaks using a flame. The correct way is to smear the joint with soapy water. If bubbles form, then there is a gas leak. Immediately turn off the gas supply first closing the control valve on the gas cylinder and then the appliance valves. Check that all the connections are properly fitted. Re-check with soapy water. If a gas leak persists, return the product to your dealer for inspection/repair.
9. Do not modify the appliance or use it for anything other than what it has been designed.
10. During use, part of the appliance will become hot, particularly the cooking areas and top. Avoid touching hot parts with your bare hands. The use of oven gloves is recommended.
12. Keep young children away from the appliance at all times.
13. This appliance consumes oxygen and needs ventilation for optimum performance and for the safety of those in close proximity.

**WARNING****Burn Hazard.**

Do not touch hot food, liquid or heating surfaces while equipment is heating or operating

Hot surfaces and food can burn skin. Allow the hot surfaces to cool before handling

DAILY CLEANING AND MAINTENANCE

There are no predetermined maintenance intervals for this appliance but the following should be observed.

1. Inspect hoses and replace if they are not in order, before using the appliance as cracked and perished hoses can be dangerous replace if necessary with hoses as detailed in point 5.
2. Allow the appliance to cool sufficiently before attempting any maintenance.
3. The appliance is fitted with a jet to regulate the correct amount of gas. The small hole in the jet may become blocked, resulting in a small flame or no flame on the burner. To clean, unscrew it from the appliance
Clean the jet by blowing the hexagon end, or by using a jet cleaner. Do not attempt to clean the jet with a sharp object, as this will damage the very small jet aperture and cause the unit to malfunction. If the jet still does not function, replace it with a new jet of the correct size. To re-assemble, reverse the above procedures.
4. Check that the flexible hose is completely connected over the nozzles at each end of the tubing and that it is held firmly in place by hose clamps. Examine the flexible hose regularly, at least each time the gas cylinder is changed and ask your dealer to fit a new LPG hose if it becomes perished, worn or damaged.
5. Only LPG hose that complies with SANS 1156-2 or BS 3212 may be used with this appliance.



THIS APPLIANCE SHOULD NOT BE CLEANED WITH A WATER JET OR IMMERSED IN WATER.